

Product Summary

$V_{(BR)DSS}$	$R_{DS(on)TYP}$	I_D
100V	76m Ω @10V	3A
	80m Ω @4.5V	

Feature

- Trench Technology Power MOSFET
- Low $R_{DS(ON)}$
- Low Gate Charge

Application

- Load Switch
- DC/DC Converter

MARKING:

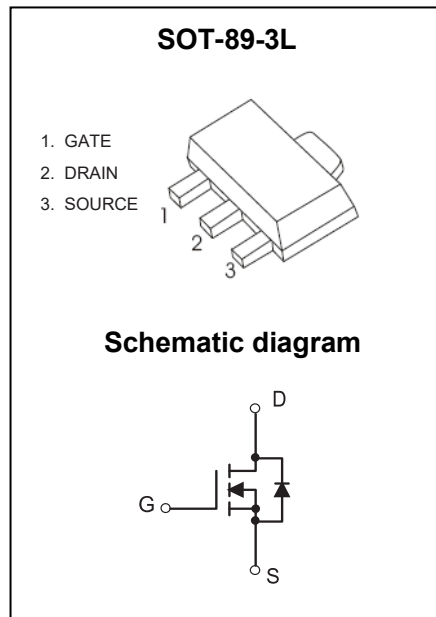
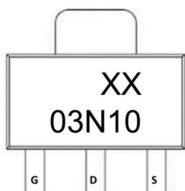

ABSOLUTE MAXIMUM RATINGS ($T_A = 25^\circ\text{C}$ unless otherwise noted)

Parameter	Symbol	Value	Unit
Drain - Source Voltage	V_{DS}	100	V
Gate - Source Voltage	V_{GS}	± 20	V
Continuous Drain Current ^{1,5}	$T_A = 25^\circ\text{C}$	I_D	3
	$T_C = 25^\circ\text{C}$	I_D	6
Pulsed Drain Current ²	I_{DM}	12	A
Power Dissipation ^{4,5}	$T_A = 25^\circ\text{C}$	P_D	1.5
	$T_C = 25^\circ\text{C}$	P_D	2.7
Thermal Resistance from Junction to Ambient ⁵	$R_{\theta JA}$	80	$^\circ\text{C/W}$
Thermal Resistance from Junction to Case	$R_{\theta JC}$	45	
Junction Temperature	T_J	150	$^\circ\text{C}$
Storage Temperature	T_{STG}	-55~ +150	$^\circ\text{C}$

Electrical Characteristics ($T_A=25^\circ\text{C}$ unless otherwise noted)

Parameter	Symbol	Test Condition	Min	Type	Max	Unit
Off Characteristics						
Drain - Source Breakdown Voltage	$V_{(BR)DSS}$	$V_{GS} = 0V, I_D = 250\mu A$	100			V
Zero Gate Voltage Drain Current	I_{DSS}	$V_{DS} = 100V, V_{GS} = 0V$			1	μA
Gate - Body Leakage Current	I_{GSS}	$V_{GS} = \pm 20V, V_{DS} = 0V$			± 100	nA
On Characteristics³						
Gate Threshold Voltage	$V_{GS(th)}$	$V_{DS} = V_{GS}, I_D = 250\mu A$	1	1.6	3	V
Drain-source On-resistance	$R_{DS(on)}$	$V_{GS} = 10V, I_D = 3A$		76	100	m Ω
		$V_{GS} = 4.5V, I_D = 3A$		80	110	
Dynamic Characteristics						
Input Capacitance	C_{iss}	$V_{DS} = 50V, V_{GS} = 0V, f = 1MHz$		1055		pF
Output Capacitance	C_{oss}			36		
Reverse Transfer Capacitance	C_{rss}			30		
Gate Resistance	R_g	$V_{DS} = 0V, V_{GS} = 0V, f = 1MHz$		1.2		Ω
Switching Characteristics						
Total Gate Charge	Q_g	$V_{DS} = 50V, V_{GS} = 10V, I_D = 3A$		27		nC
Gate-source Charge	Q_{gs}			2.6		
Gate-drain Charge	Q_{gd}			6.8		
Turn-on Delay Time	$t_{d(on)}$	$V_{DD} = 50V, V_{GS} = 10V, R_L = 17\Omega,$ $R_G = 3\Omega$		17		ns
Turn-on Rise Time	t_r			7		
Turn-off Delay Time	$t_{d(off)}$			35		
Turn-off Fall Time	t_f			6		
Source - Drain Diode Characteristics						
Diode Forward Voltage ³	V_{SD}	$V_{GS} = 0V, I_S = 3A$			1.2	V

Notes :

- 1.The maximum current rating is limited by package.
- 2.Pulse Test : Pulse Width $\leq 10\mu s$, duty cycle $\leq 1\%$.
- 3.Pulse Test : Pulse Width $\leq 300\mu s$, duty cycle $\leq 2\%$.
- 4.The power dissipation P_D is limited by $T_{J(MAX)} = 150^\circ\text{C}$.
- 5.Device mounted on 1in^2 FR-4 board with 2oz. Copper, in a still air environment with $T_A = 25^\circ\text{C}$.

Typical Characteristics

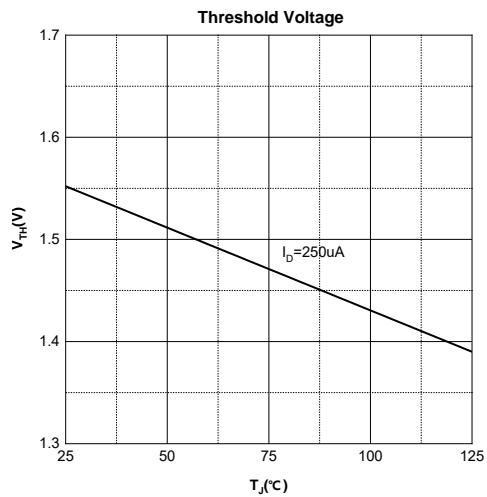
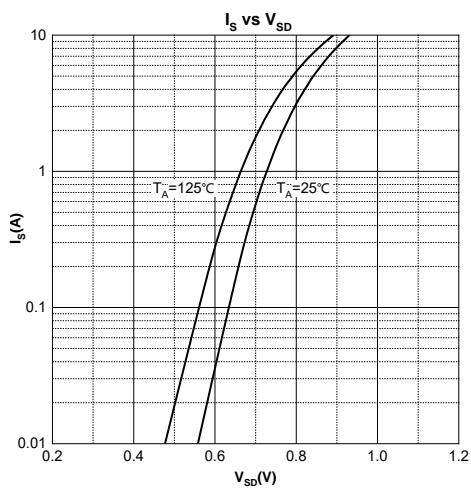
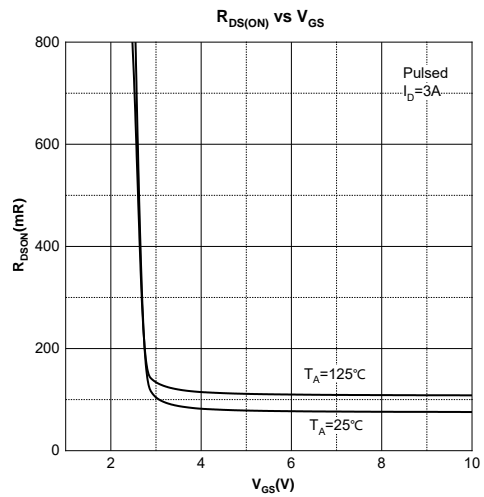
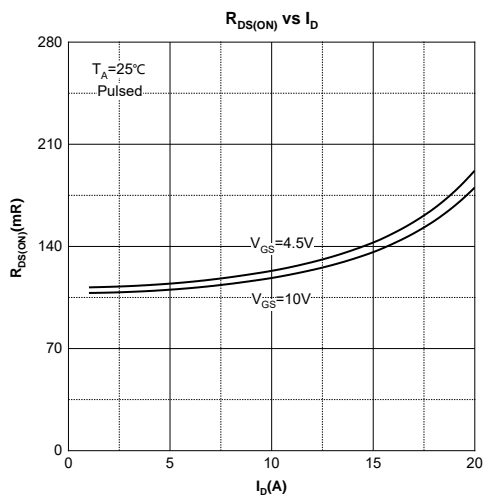
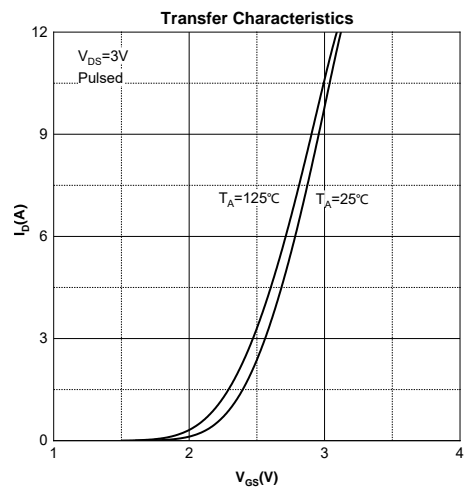
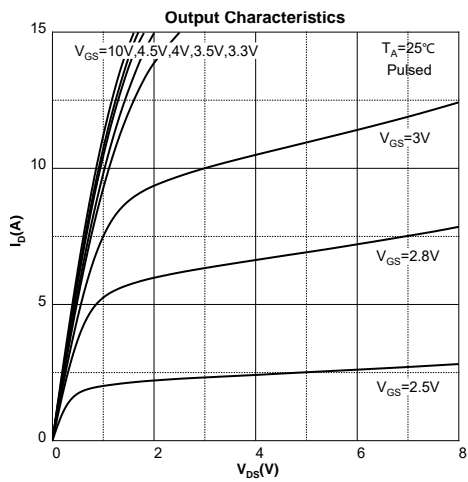

SOT-89-3L Package Outline Dimensions

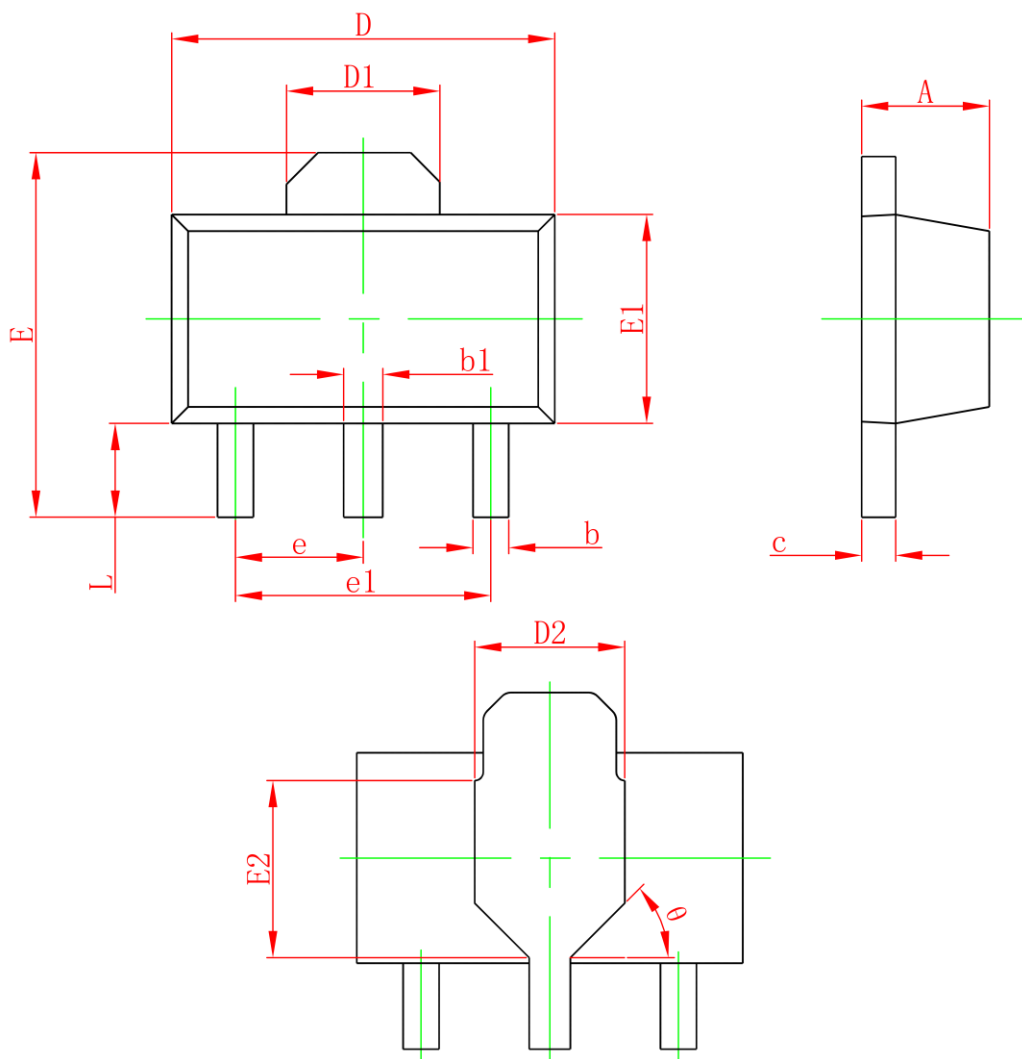

Symbol	Dimensions In Millimeters		Dimensions In Inches	
	Min.	Max.	Min.	Max.
A	1.400	1.600	0.055	0.063
b	0.320	0.520	0.013	0.020
b1	0.380	0.580	0.015	0.023
c	0.350	0.500	0.014	0.020
D	4.400	4.600	0.173	0.181
D1	1.650REF		0.065REF	
D2	1.650	1.850	0.065	0.073
E	3.900	4.400	0.154	0.173
E1	2.300	2.600	0.091	0.102
E2	1.900REF		0.075REF	
e	1.500TYP		0.059TYP	
e1	3.000TYP		0.118TYP	
L	0.900	1.200	0.035	0.047
θ	45°		45°	