

## 40V N- and P- Channel MOSFET

### Product Summary

$V_{(BR)DSS}$	$R_{DS(on)TYP}$	$I_D$
-40V	31mΩ@-10V	-7A
	39mΩ@-4.5V	
40V	16mΩ@10V	9A
	27mΩ@4.5V	

### Feature

- Low drain-source ON-resistance
- High forward transfer admittance
- Low leakage current

### Application

- Low voltage applications

### MARKING:

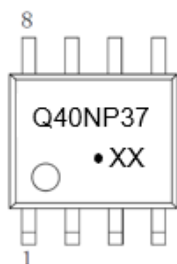

Q40NP37 = Device Code  
 XX = Date Code  
 Solid dot = Green Device

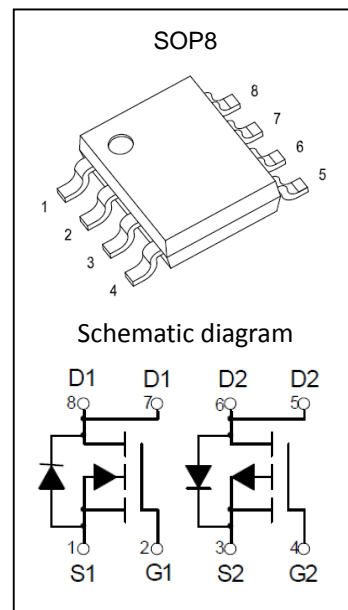

### ABSOLUTE MAXIMUM RATINGS ( $T_A=25^{\circ}\text{C}$ unless otherwise noted)

Parameter	Symbol	Value	Unit
<b>P-MOSFET</b>			
Drain-Source Voltage	$V_{DS}$	-40	V
Gate-Source Voltage	$V_{GS}$	±20	V
Continuous Drain Current <sup>(1)</sup>	$I_D$	-7	A
Pulsed Drain Current	$I_{DM}$	-21	A
Power Dissipation	$P_D$	1.4	W
<b>N-MOSFET</b>			
Drain-Source Voltage	$V_{DS}$	40	V
Gate-Source Voltage	$V_{GS}$	±20	V
Continuous Drain Current	$I_D$	9	A
Pulsed Drain Current <sup>(1)</sup>	$I_{DM}$	27	A
Power Dissipation	$P_D$	1.4	W
<b>Temperature and Thermal Resistance</b>			
Thermal Resistance from Junction to Ambient <sup>(2)</sup>	$R_{\theta JA}$	89	°C/W
Junction Temperature	$T_J$	150	°C
Storage Temperature	$T_{STG}$	-55~ +150	°C

**P-channel MOSFET ELECTRICAL CHARACTERISTICS(T<sub>A</sub>=25°C unless otherwise noted)**

Parameter	Symbol	Test Condition	Min	Type	Max	Unit
<b>Static Characteristics</b>						
Drain-source Breakdown Voltage	V <sub>(BR)DSS</sub>	V <sub>GS</sub> = 0V, I <sub>D</sub> = -250μA	-40			V
Zero Gate Voltage Drain Current	I <sub>DSS</sub>	V <sub>DS</sub> = -32V, V <sub>GS</sub> = 0V			-1	μA
Gate-body Leakage Current	I <sub>GSS</sub>	V <sub>GS</sub> = ±20V, V <sub>DS</sub> = 0V			±100	nA
Gate Threshold Voltage	V <sub>GS(th)</sub>	V <sub>DS</sub> = V <sub>GS</sub> , I <sub>D</sub> = -250μA	-1.0	-1.6	-3.0	V
Drain-source On-resistance <sup>(3)</sup>	R <sub>DSON</sub>	V <sub>GS</sub> = -10V, I <sub>D</sub> = -5.0A		31	37	mΩ
		V <sub>GS</sub> = -4.5V, I <sub>D</sub> = -5.0A		39	47	
Forward Transconductance	g <sub>FS</sub>	V <sub>DS</sub> = -5V, I <sub>D</sub> = -5.0A	5			S
<b>Dynamic Characteristics<sup>(4)</sup></b>						
Input Capacitance	C <sub>iss</sub>	V <sub>DS</sub> = -20V, V <sub>GS</sub> = 0V, F = 1.0MHz		850		pF
Output Capacitance	C <sub>oss</sub>			101		
Reverse Transfer Capacitance	C <sub>rss</sub>			65		
Total Gate Charge	Q <sub>g</sub>	V <sub>DS</sub> = -20V, I <sub>D</sub> = -5A, V <sub>GS</sub> = -4.5V		9.5		nC
Gate-source Charge	Q <sub>gs</sub>			2		
Gate-drain Charge	Q <sub>gd</sub>			3		
<b>Switching Characteristics<sup>(4)</sup></b>						
Turn-on Delay Time	t <sub>d(on)</sub>	V <sub>DD</sub> = -20V, I <sub>D</sub> = -5A V <sub>GS</sub> = -10V, R <sub>GEN</sub> = 6Ω		7		ns
Turn-on Rise Time	t <sub>r</sub>			3		
Turn-off Delay Time	t <sub>d(off)</sub>			20		
Turn-off Fall Time	t <sub>f</sub>			12		
<b>Source - Drain Diode Characteristics</b>						
Diode Forward Voltage <sup>(3)</sup>	V <sub>SD</sub>	I <sub>S</sub> = -1.0A, V <sub>GS</sub> = 0V			-1.2	V
Reverse Recovery Time	t <sub>rr</sub>	I <sub>F</sub> = -10A, di/dt = 100A/us		32		ns

## N-channel MOSFET ELECTRICAL CHARACTERISTICS( $T_A=25^\circ\text{C}$ unless otherwise noted)

Parameter	Symbol	Test Condition	Min	Type	Max	Unit
<b>Static Characteristics</b>						
Drain-source Breakdown Voltage	$V_{(BR)DSS}$	$V_{GS} = 0V, I_D = 250\mu A$	40			V
Zero Gate Voltage Drain Current	$I_{DSS}$	$V_{DS} = 32V, V_{GS} = 0V$			1	$\mu A$
Gate-body Leakage Current	$I_{GSS}$	$V_{GS} = \pm 20V, V_{DS} = 0V$			$\pm 100$	nA
Gate Threshold Voltage	$V_{GS(th)}$	$V_{DS} = V_{GS}, I_D = 250\mu A$	1.0	1.6	3.0	V
Drain-source On-resistance <sup>(3)</sup>	$R_{DS(on)}$	$V_{GS} = 10V, I_D = 6.0A$		16	21	m $\Omega$
		$V_{GS} = 4.5V, I_D = 6.0A$		27	32	
Forward Transconductance	$g_{FS}$	$V_{DS} = 5V, I_D = 6.0A$	10			S
<b>Dynamic Characteristics<sup>(4)</sup></b>						
Input Capacitance	$C_{iss}$	$V_{DS} = 20V, V_{GS} = 0V, F = 1.0MHz$		633		pF
Output Capacitance	$C_{oss}$			65		
Reverse Transfer Capacitance	$C_{riss}$			55		
Total Gate Charge	$Q_g$	$V_{DS} = 20V, I_D = 6.0A, V_{GS} = 4.5V$		9.5		nC
Gate-source Charge	$Q_{gs}$			1.5		
Gate-drain Charge	$Q_{gd}$			3		
<b>Switching Characteristics<sup>(4)</sup></b>						
Turn-on Delay Time	$t_{d(on)}$	$V_{DD} = 20V, R_L = 2.7\Omega$ $V_{GS} = 10V, R_{GEN} = 3\Omega$		3.3		ns
Turn-on Rise Time	$t_r$			4.8		
Turn-off Delay Time	$t_{d(off)}$			26		
Turn-off Fall Time	$t_f$			4		
<b>Source - Drain Diode Characteristics</b>						
Diode Forward Voltage <sup>(3)</sup>	$V_{SD}$	$I_S = 1.0A, V_{GS} = 0V$			1.2	V
Reverse Recovery Time	$t_{rr}$	$I_F = 4A, di/dt = 100A/\mu s$		16		ns

### Notes:

1. Repetitive Rating : Pulse width limited by maximum junction temperature.
2. Surface Mounted on FR4 Board,  $t < 5$  sec.
3. Pulse Test : Pulse Width  $\leq 300\mu s$ , Duty Cycle  $\leq 2\%$ .
4. Guaranteed by design, not subject to production testing.

# Typical Characteristics

## P-Channel MOS

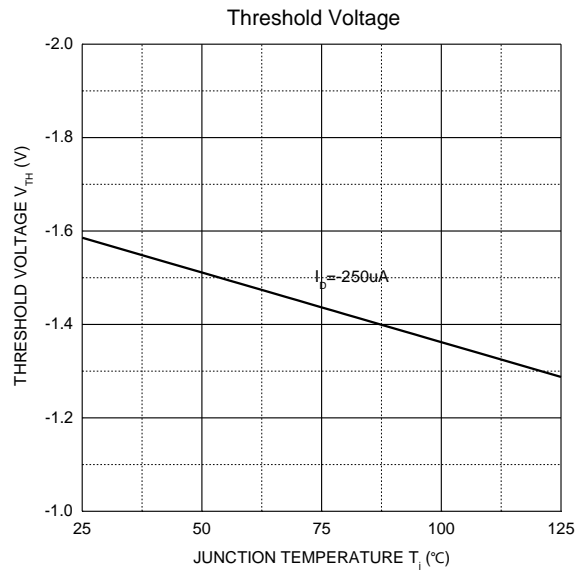
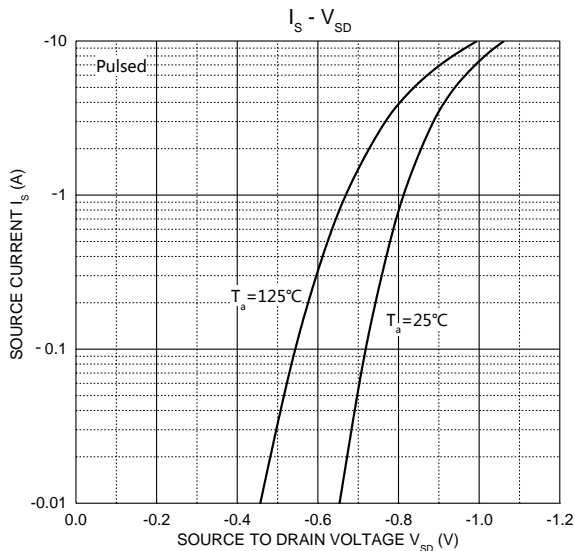
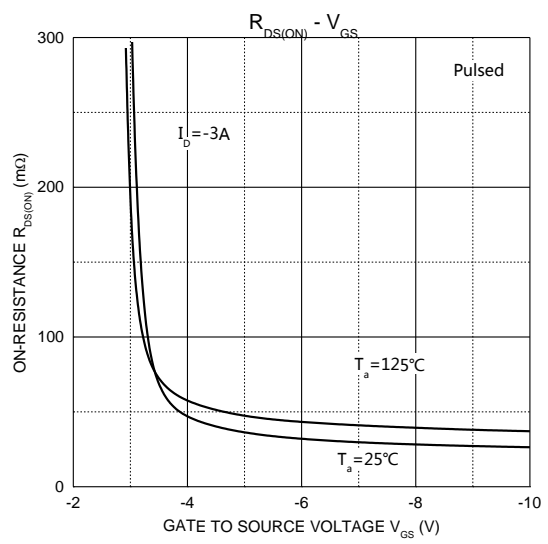
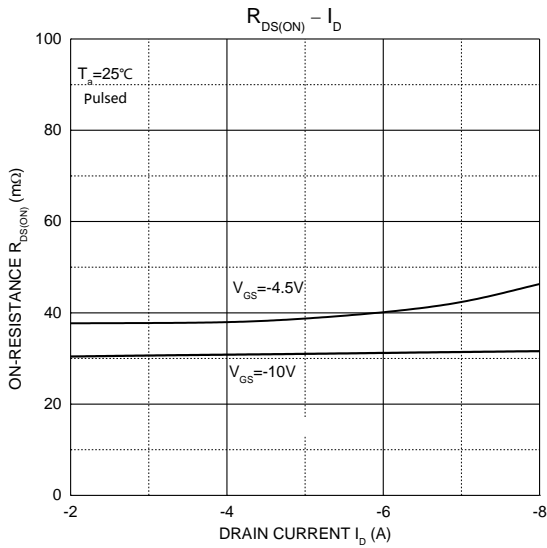
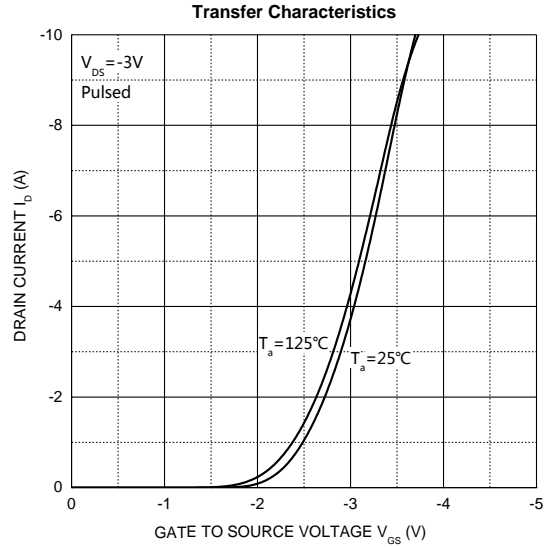
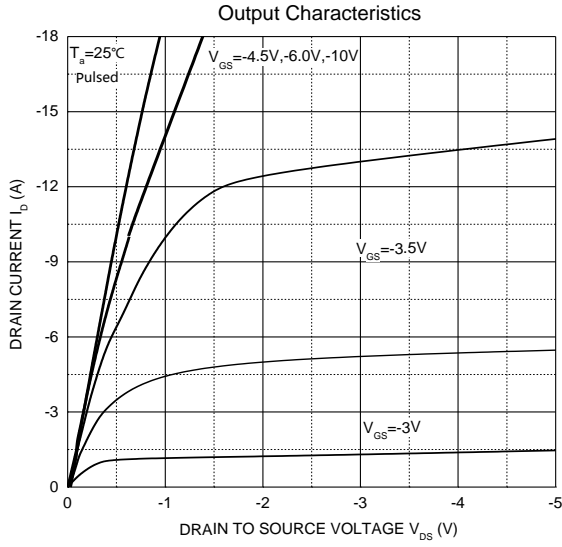

# Typical Characteristics

N-Channel MOS

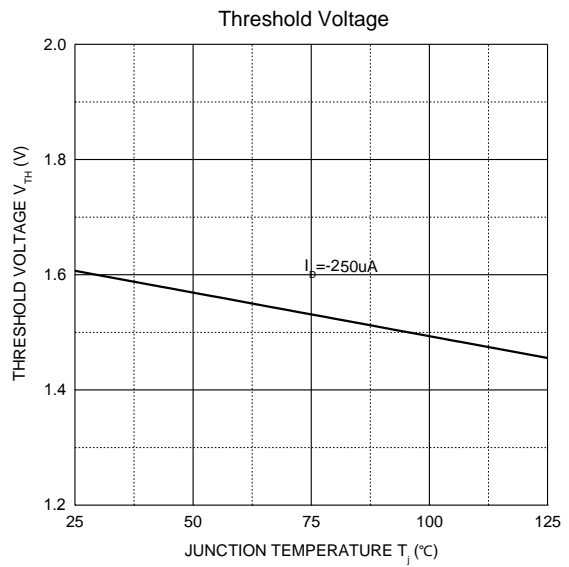
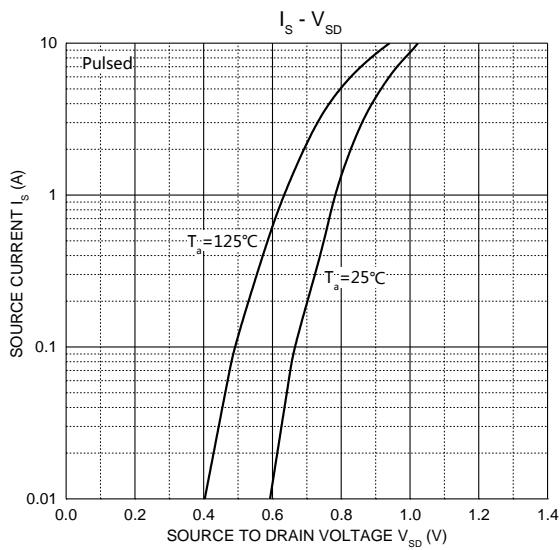
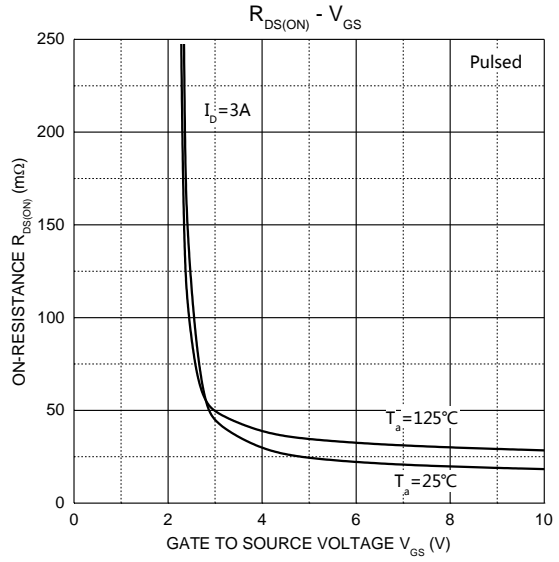
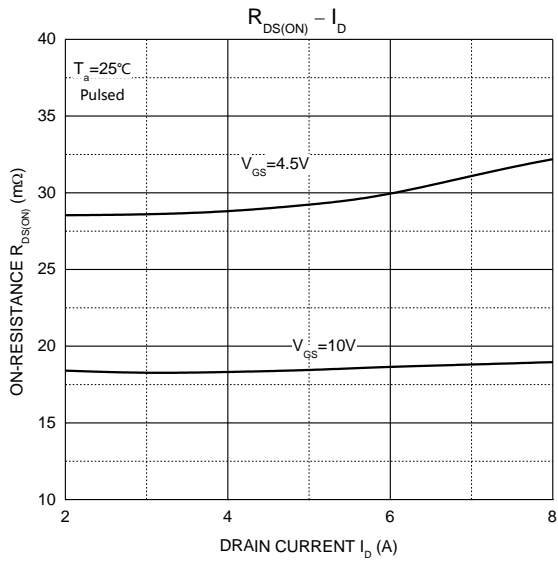
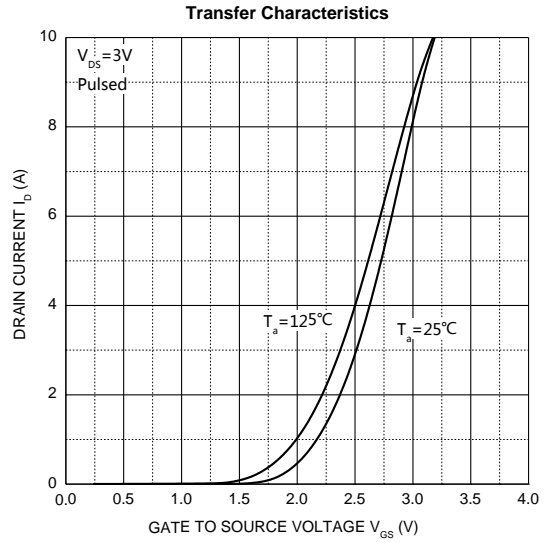
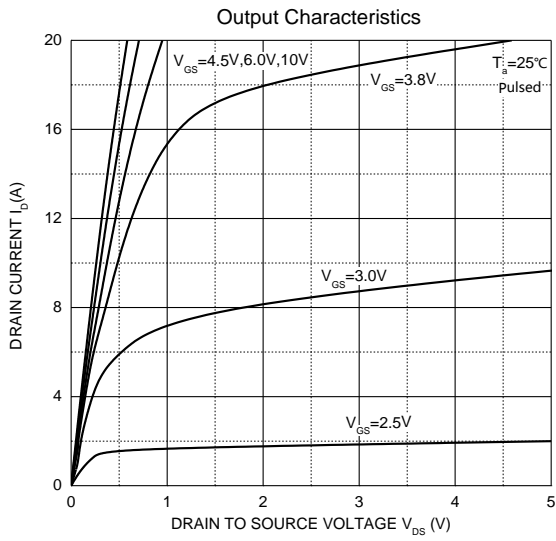

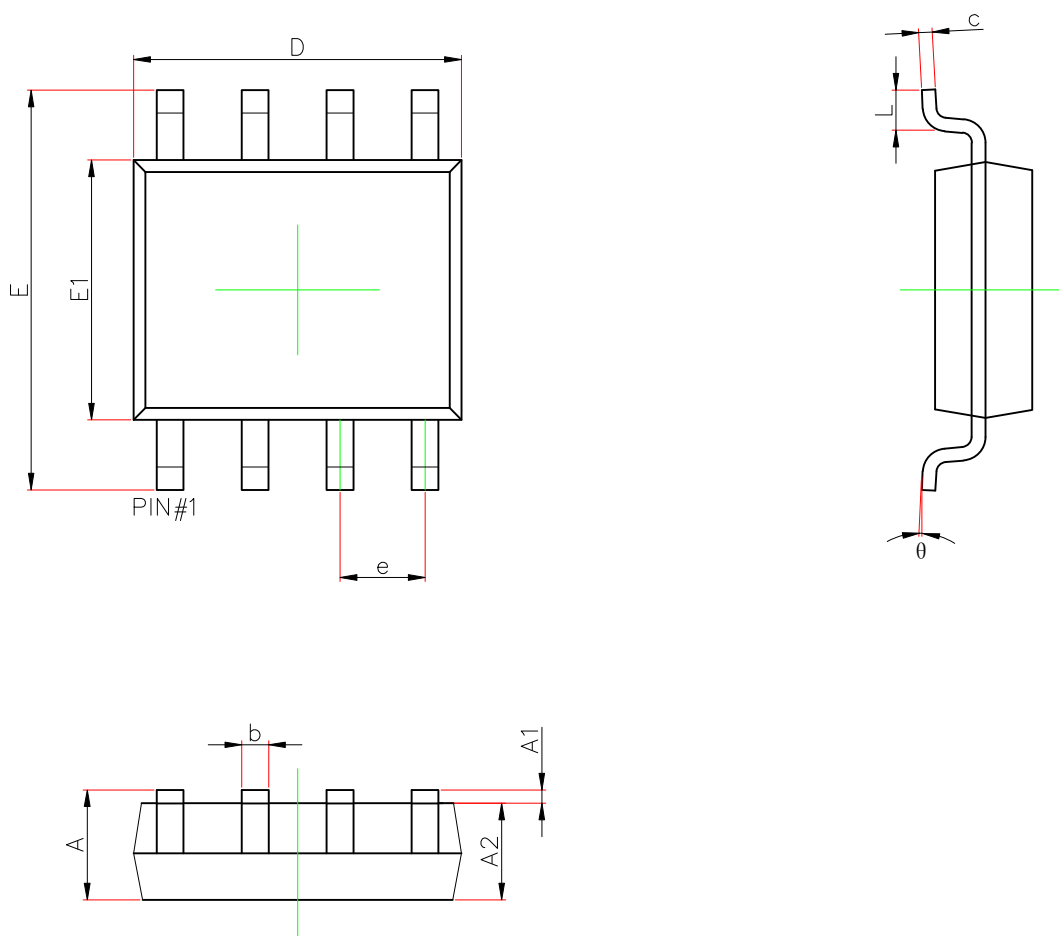

Symbol	Dimensions In Millimeters		Dimensions In Inches	
	Min.	Max.	Min.	Max.
A	1.350	1.750	0.053	0.069
A1	0.100	0.250	0.004	0.010
A2	1.350	1.550	0.053	0.061
b	0.330	0.510	0.013	0.020
c	0.156	0.250	0.006	0.010
D	4.700	5.100	0.185	0.201
e	1.270(BSC)		0.050(BSC)	
E	5.800	6.200	0.228	0.244
E1	3.700	4.100	0.146	0.161
L	0.400	1.270	0.016	0.05
θ	0°	8°	0°	8°