

30V N- and P- Channel MOSFET

Product Summary

V _{(BR)DSS}	R _{DS(on)TYP}	I _D
30V	32mΩ@10V	4.6A
	35mΩ@4.5V	
	42mΩ@2.5V	
-30V	62mΩ@-10V	-3.4A
	76mΩ@-4.5V	
	104mΩ@-2.5V	

Feature

- Trench Technology Power MOSFET
- Low R_{DS(ON)}
- Low Gate Charge

Application

- Load Switch
- DC/DC Converter
- Power Management Functions

MARKING:

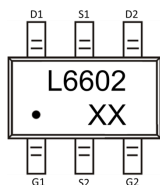

L6602 = Device Code
XX = Data Code

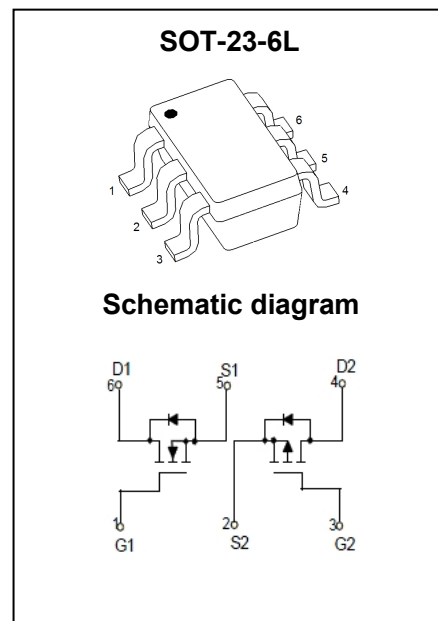

ABSOLUTE MAXIMUM RATINGS (T_A = 25°C unless otherwise noted)

Parameter	Symbol	Value	Value	Unit
Drain - Source Voltage	V _{DS}	30	-30	V
Gate - Source Voltage	V _{GS}	±12	±12	V
Continuous Drain Current ^{1,5}	I _D	4.6	-3.4	A
T _A = 25°C				
Pulsed Drain Current ²	I _{DM}	18	-13	A
Power Dissipation ^{4,5}	P _D	0.36	0.36	W
T _A = 25°C				
Thermal Resistance from Junction to Ambient ⁵	R _{θJA}	347	347	°C/W
Junction Temperature	T _J	150	150	°C
Storage Temperature	T _{STG}	-55~ +150	-55~ +150	°C
Thermal Resistance from Junction to Case	R _{θJC}	7.4	8.3	°C/W
Junction Temperature				
Storage Temperature	T _{STG}	-55~ +150	-55~ +150	°C

MOSFET ELECTRICAL CHARACTERISTICS (T_J = 25°C unless otherwise noted)

NMOS:

Parameter	Symbol	Test Condition	Min	Type	Max	Unit
Off Characteristics						
Drain - Source Breakdown Voltage	V _{(BR)DSS}	V _{GS} = 0V, I _D = 250μA	30			V
Zero Gate Voltage Drain Current	I _{DSS}	V _{DS} = 24V, V _{GS} = 0V			1	μA
Gate - Body Leakage Current	I _{GSS}	V _{GS} = ±12V, V _{DS} = 0V			±100	nA
On Characteristics³						
Gate Threshold Voltage	V _{GS(th)}	V _{DS} = V _{GS} , I _D = 250μA	0.6	0.9	1.4	V
Drain-source On-resistance	R _{DS(on)}	V _{GS} = 10V, I _D = 3.0A		32	60	mΩ
		V _{GS} = 4.5V, I _D = 3.0A		35	75	
		V _{GS} = 2.5V, I _D = 2.0A		42	115	
Forward tranconductance	g _{FS}	V _{DS} = 5V, I _D = 3A	5			S
Dynamic Characteristics						
Input Capacitance	C _{iSS}	V _{DS} = 15V, V _{GS} = 0V, f = 1MHz		458		pF
Output Capacitance	C _{oss}			38		
Reverse Transfer Capacitance	C _{rSS}			33		
Gate Resistance	R _g	V _{DS} = 0V, V _{GS} = 0V, f = 1MHz		1.4		Ω
Switching Characteristics						
Total Gate Charge	Q _g	V _{DS} = 15V, V _{GS} = 10V, I _D = 3.0A		11.9		nC
Gate-source Charge	Q _{gs}			1.0		
Gate-drain Charge	Q _{gd}			1.6		
Turn-on Delay Time	t _{d(on)}	V _{DD} = 15V, V _{GS} = 10V, R _L = 5Ω, R _G = 6Ω		5		ns
Turn-on Rise Time	t _r			6		
Turn-off Delay Time	t _{d(off)}			20		
Turn-off Fall Time	t _f			4		
Source - Drain Diode Characteristics						
Diode Forward Voltage ³	V _{SD}	V _{GS} = 0V, I _S = 1.0A			1.2	V

MOSFET ELECTRICAL CHARACTERISTICS ($T_J = 25^\circ\text{C}$ unless otherwise noted)

PMOS:

Parameter	Symbol	Test Condition	Min	Type	Max	Unit
Off Characteristics						
Drain - Source Breakdown Voltage	$V_{(BR)DSS}$	$V_{GS} = 0V, I_D = -250\mu A$	-30			V
Zero Gate Voltage Drain Current	I_{DSS}	$V_{DS} = -24V, V_{GS} = 0V$			1	μA
Gate - Body Leakage Current	I_{GSS}	$V_{GS} = \pm 12V, V_{DS} = 0V$			± 100	nA
On Characteristics³						
Gate Threshold Voltage	$V_{GS(th)}$	$V_{DS} = V_{GS}, I_D = -250\mu A$	-0.6	-0.9	-1.4	V
Drain-source On-resistance	$R_{DS(on)}$	$V_{GS} = -10V, I_D = -2.3A$		62	135	m Ω
		$V_{GS} = -4.5V, I_D = -2.0A$		76	185	
		$V_{GS} = -2.5V, I_D = -1.0A$		104	265	
Forward transconductance	g_{FS}	$V_{DS} = -5V, I_D = -3A$	4.5			S
Dynamic Characteristics						
Input Capacitance	C_{iss}	$V_{DS} = -15V, V_{GS} = 0V, f = 1MHz$		394		pF
Output Capacitance	C_{oss}			46		
Reverse Transfer Capacitance	C_{rss}			40		
Gate Resistance	R_g	$V_{DS} = 0V, V_{GS} = 0V, f = 1MHz$		5.4		Ω
Switching Characteristics						
Total Gate Charge	Q_g	$V_{DS} = -15V, V_{GS} = -10V, I_D = -2.3A$		10.7		nC
Gate-source Charge	Q_{gs}			1.0		
Gate-drain Charge	Q_{gd}			1.4		
Turn-on Delay Time	$t_{d(on)}$	$V_{DD} = -15V, V_{GS} = -10V,$ $R_L = 5\Omega, R_G = 6\Omega$		12		ns
Turn-on Rise Time	t_r			10		
Turn-off Delay Time	$t_{d(off)}$			25		
Turn-off Fall Time	t_f			11		
Source - Drain Diode Characteristics						
Diode Forward Voltage ³	V_{SD}	$V_{GS} = 0V, I_S = -1.0A$			1.2	V

Notes :

- 1.The maximum current rating is limited by package.
- 2.Pulse Test : Pulse Width $\leq 10\mu s$, duty cycle $\leq 1\%$.
- 3.Pulse Test : Pulse Width $\leq 300\mu s$, duty cycle $\leq 2\%$.
- 4.The power dissipation P_D is limited by $T_{J(MAX)} = 150^\circ\text{C}$.
- 5.Device mounted on 1in² FR-4 board with 2oz. Copper, in a still air environment with $T_A = 25^\circ\text{C}$.

Typical Characteristics

Typical Characteristics

NMOS:

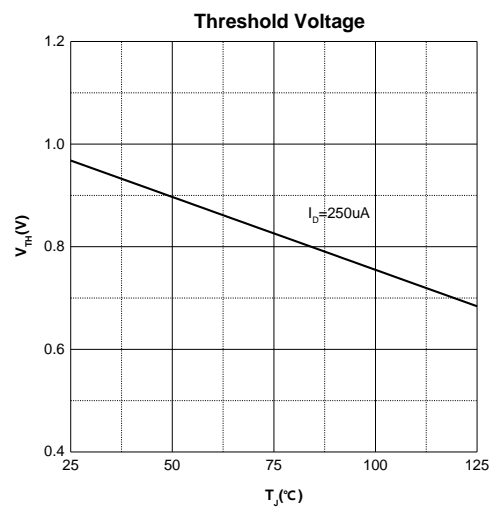
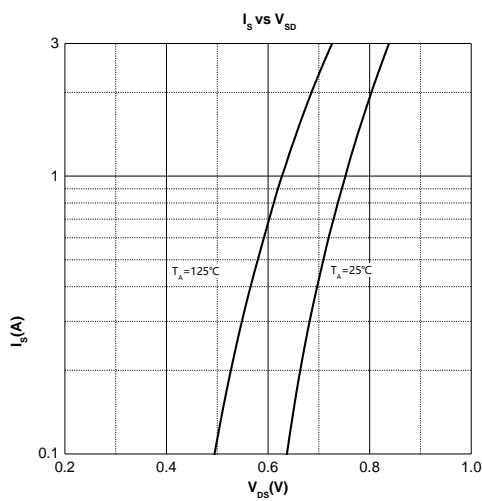
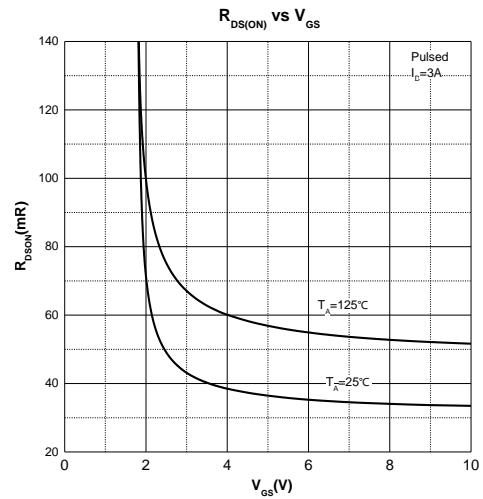
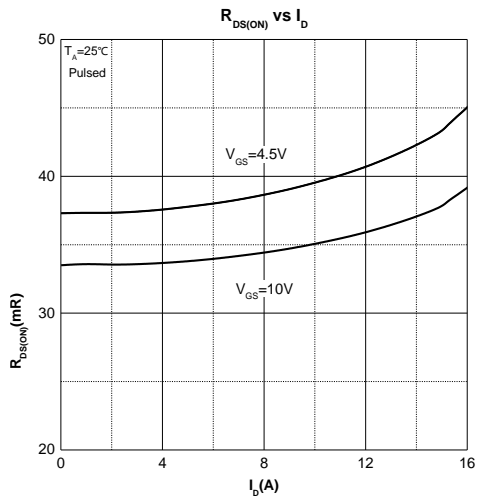
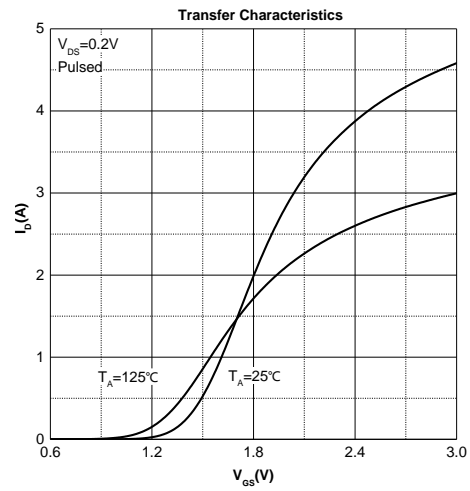
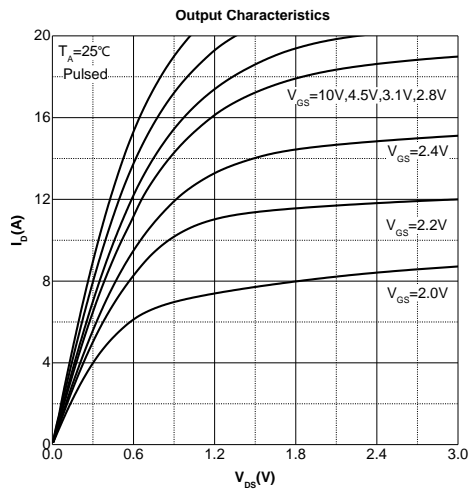

Typical Characteristics

PMOS:

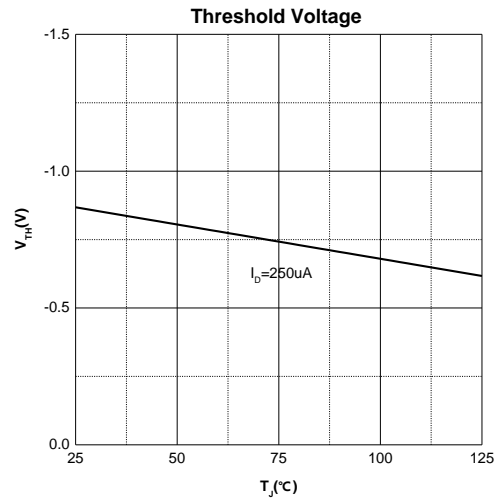
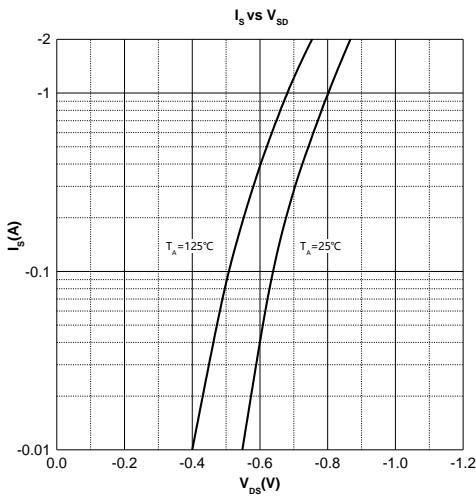
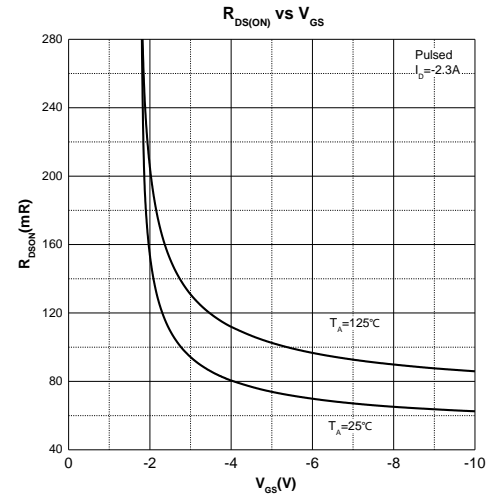
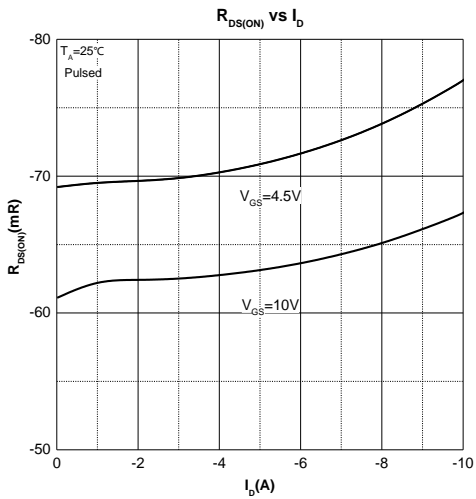
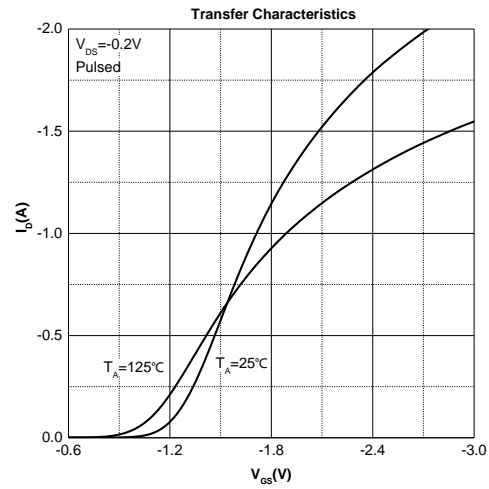
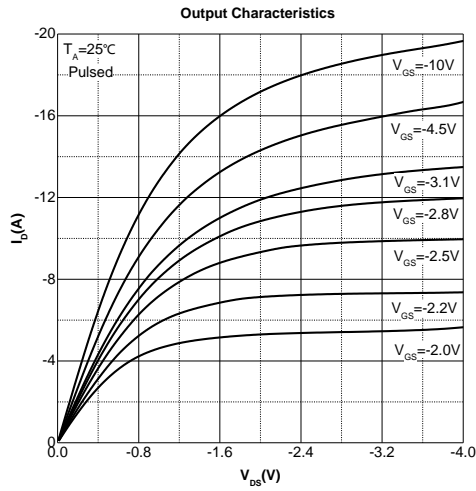

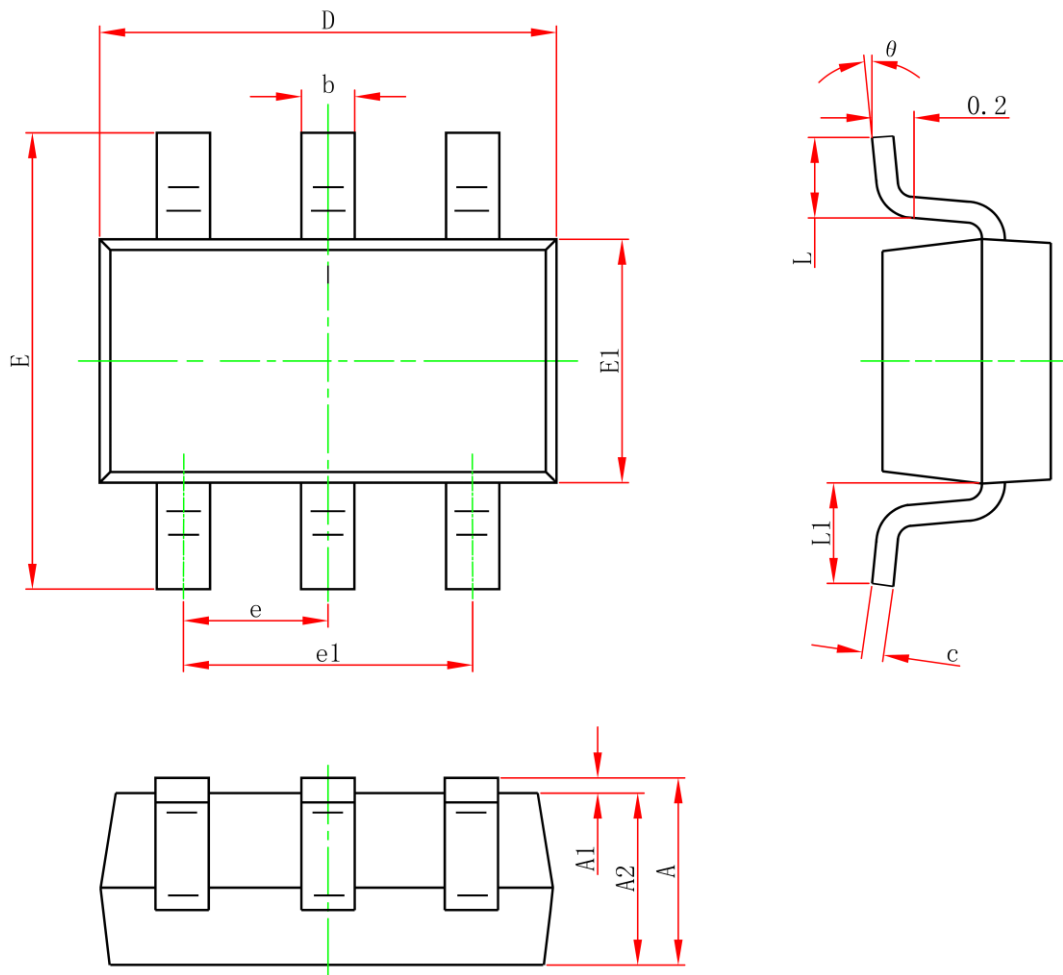

Symbol	Dimensions In Millimeters		Dimensions In Inches	
	Min.	Max.	Min.	Max.
A	1.050	1.250	0.041	0.049
A1	0	0.150	0.000	0.006
A2	1.050	1.250	0.041	0.049
b	0.300	0.500	0.012	0.020
c	0.100	0.200	0.004	0.008
D	2.820	3.020	0.111	0.119
E	2.650	2.950	0.104	0.116
E1	1.500	1.700	0.059	0.067
e	0.950TYP		0.037TYP	
e1	1.800	2.000	0.071	0.079
L	0.300	0.600	0.012	0.024
L1	0.600REF		0.024REF	
θ	0°	8°	0°	8°