

8V N-Channel MOSFET

Product Summary

$V_{(BR)DSS}$	$R_{DS(on)TYP}$	I_D
80V	4.5m Ω @10V	130A

Feature

- Split Gate Trench Technology
- Low $R_{DS(on)}$
- Low Gate Charge
- Low Gate Resistance
- 100% UIS Tested

Application

- Power Switching Application
- Power Management
- BLDC Motor Drive Systems

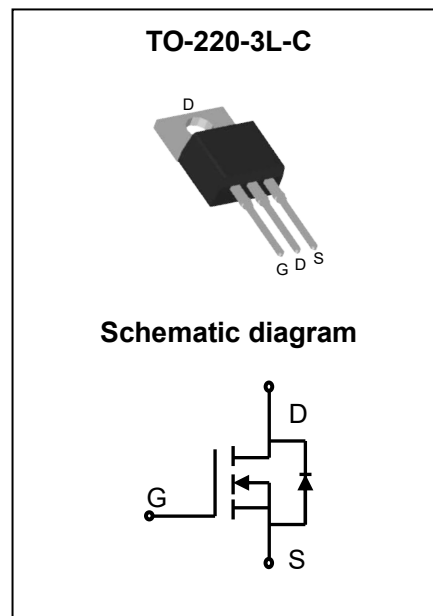

Package Marking and Ordering Information

Part Number	Package	Marking	Packing	Reel Size	Tape Width	Qty
T1933NTB	TO-220-3L-C	T1933	Tube	-	-	50pcs

ABSOLUTE MAXIMUM RATINGS ($T_A = 25^\circ\text{C}$ unless otherwise noted)

Parameter	Symbol	Value	Unit	
Drain - Source Voltage	V_{DS}	80	V	
Gate - Source Voltage	V_{GS}	± 20	V	
Continuous Drain Current ¹	$T_C = 25^\circ\text{C}$	I_D	130	A
	$T_C = 100^\circ\text{C}$	I_D	92	A
Pulsed Drain Current ²	I_{DM}	520	A	
Single Pulsed Avalanche Current ³	I_{AS}	42	A	
Single Pulsed Avalanche Energy ³	E_{AS}	441	mJ	
Power Dissipation ⁵	$T_C = 25^\circ\text{C}$	P_D	157	W
Thermal Resistance from Junction to Ambient ⁶	$R_{\theta JA}$	55	$^\circ\text{C/W}$	
Thermal Resistance from Junction to Case	$R_{\theta JC}$	0.8	$^\circ\text{C/W}$	
Junction Temperature	T_J	150	$^\circ\text{C}$	
Storage Temperature	T_{STG}	-55~ +150	$^\circ\text{C}$	

Electrical Characteristics ($T_A=25^\circ\text{C}$ unless otherwise noted)

Parameter	Symbol	Test Condition	Min	Type	Max	Unit
Off Characteristics						
Drain - Source Breakdown Voltage	$V_{(BR)DSS}$	$V_{GS} = 0V, I_D = 250\mu A$	80			V
Zero Gate Voltage Drain Current	I_{DSS}	$V_{DS} = 80V, V_{GS} = 0V$			1	μA
Gate - Body Leakage Current	I_{GSS}	$V_{GS} = \pm 20V, V_{DS} = 0V$			± 100	nA
On Characteristics⁴						
Gate Threshold Voltage	$V_{GS(th)}$	$V_{DS} = V_{GS}, I_D = 250\mu A$	2	2.6	4	V
Drain-source On-resistance	$R_{DS(on)}$	$V_{GS} = 10V, I_D = 50A$		4.5	7.0	m Ω
Dynamic Characteristics						
Input Capacitance	C_{iss}	$V_{DS} = 40V, V_{GS} = 0V, f = 0.1MHz$		3449		pF
Output Capacitance	C_{oss}			681		
Reverse Transfer Capacitance	C_{rss}			27		
Gate Resistance	R_g	$V_{DS} = 0V, V_{GS} = 0V, f = 1MHz$		2.5		Ω
Switching Characteristics						
Total Gate Charge	Q_g	$V_{DS} = 40V, V_{GS} = 10V, I_D = 20A$		50		nC
Gate-source Charge	Q_{gs}			16		
Gate-drain Charge	Q_{gd}			11		
Turn-on Delay Time	$t_{d(on)}$	$V_{DD} = 40V, V_{GS} = 10V, I_D = 20A,$ $R_G = 3\Omega$		16		ns
Turn-on Rise Time	t_r			13		
Turn-off Delay Time	$t_{d(off)}$			32		
Turn-off Fall Time	t_f			14		
Source - Drain Diode Characteristics						
Diode Forward Voltage ⁴	V_{SD}	$V_{GS} = 0V, I_S = 50A$			1.2	V

Notes:

1. The maximum current rating is limited by package. And device mounted on a large heatsink.
2. Pulse Test : Pulse Width $\leq 10\mu s$, duty cycle $\leq 1\%$.
3. E_{AS} condition: $V_{DD} = 80V, V_{GS} = 10V, L = 0.5mH, R_G = 25\Omega$ Starting $T_J = 25^\circ C$.
4. Pulse Test: Pulse Width $\leq 300\mu s$, duty cycle $\leq 2\%$.
5. The power dissipation P_D is limited by $T_{J(MAX)} = 150^\circ C$. And device mounted on a large heatsink
6. Device mounted on $1in^2$ FR-4 board with 2oz. Copper, in a still air environment with $T_A = 25^\circ C$.

Typical Characteristics

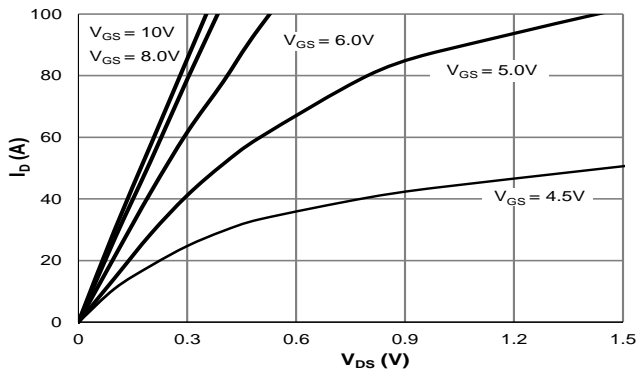

Figure 1: Saturation Characteristics

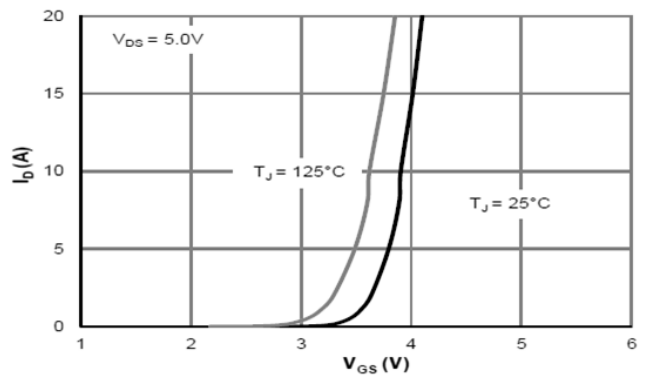

Figure 2: Transfer Characteristics

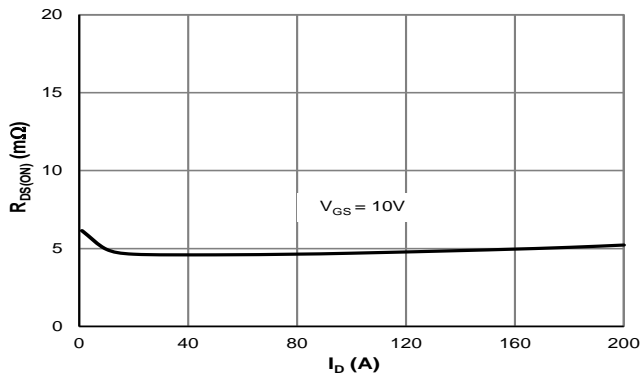

Figure 3: $R_{DS(ON)}$ vs. Drain Current

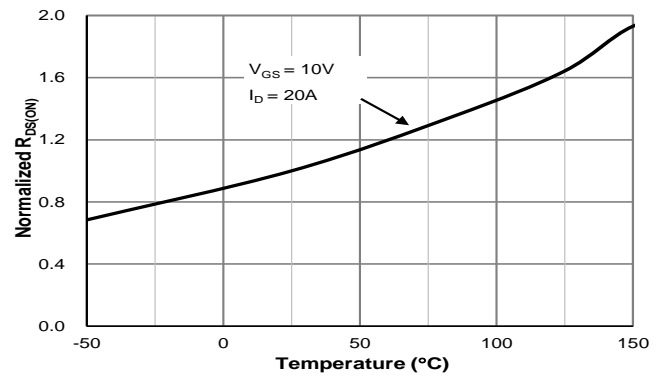

Figure 4: $R_{DS(ON)}$ vs. Junction Temperature

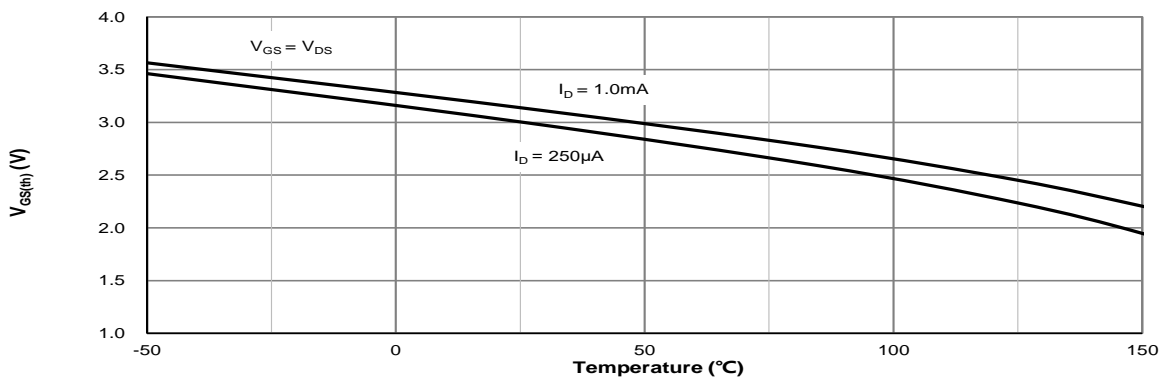

Figure 5: $V_{GS(th)}$ vs. Junction Temperature

Typical Characteristics

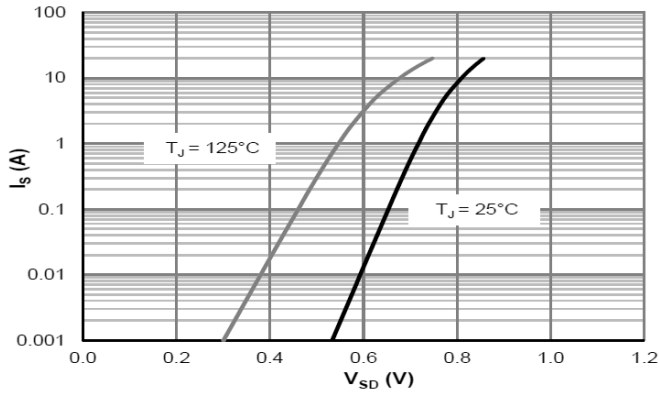

Figure 7: Body-Diode Characteristics

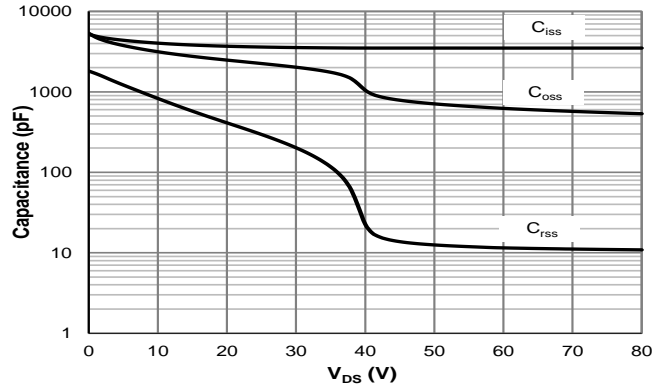

Figure 8: Capacitance Characteristics

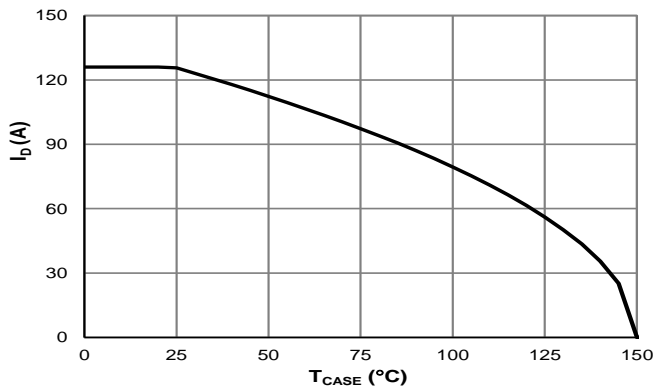

Figure 9: Current De-rating

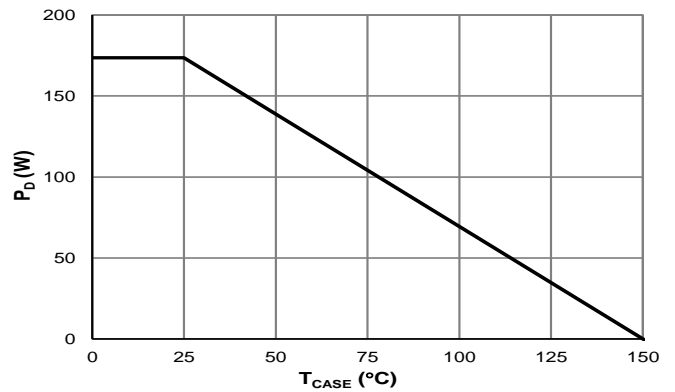

Figure 10: Power De-rating

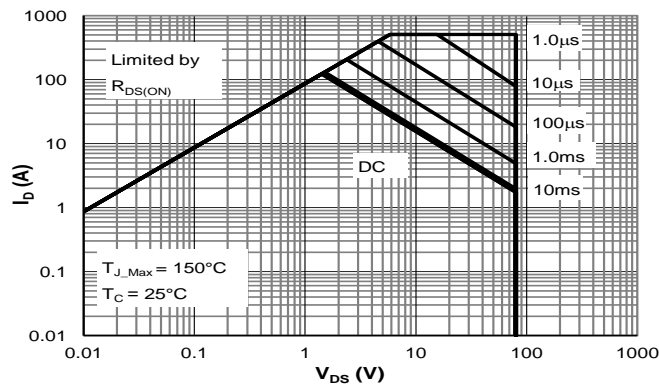

Figure 11: Maximum Safe Operating Area

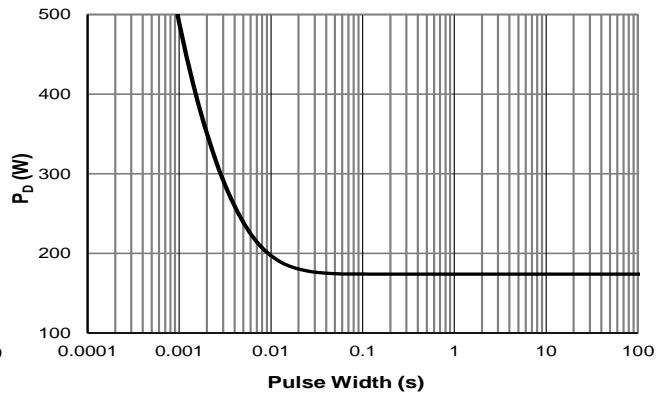

Figure 12: Single Pulse Power Rating, Junction-to-Case

Typical Characteristics

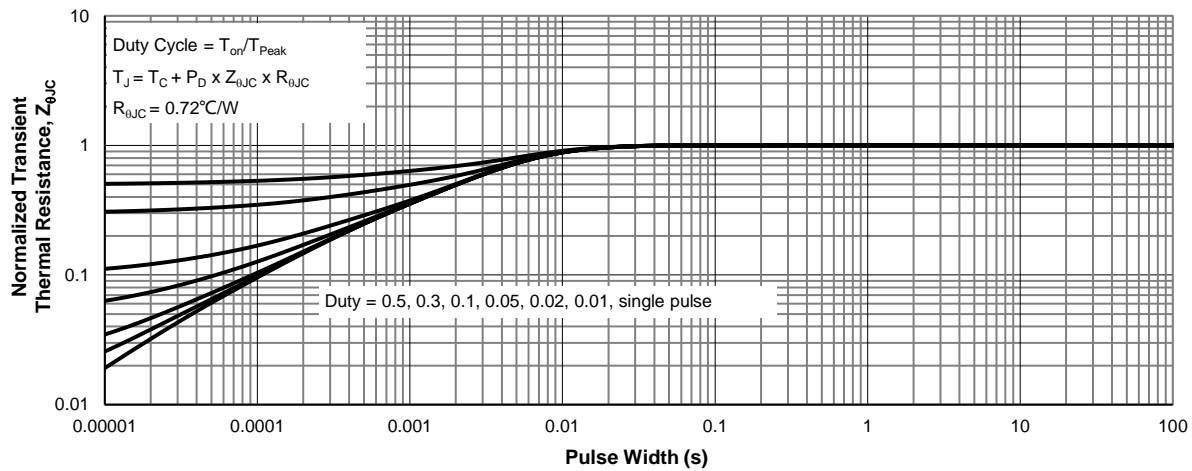
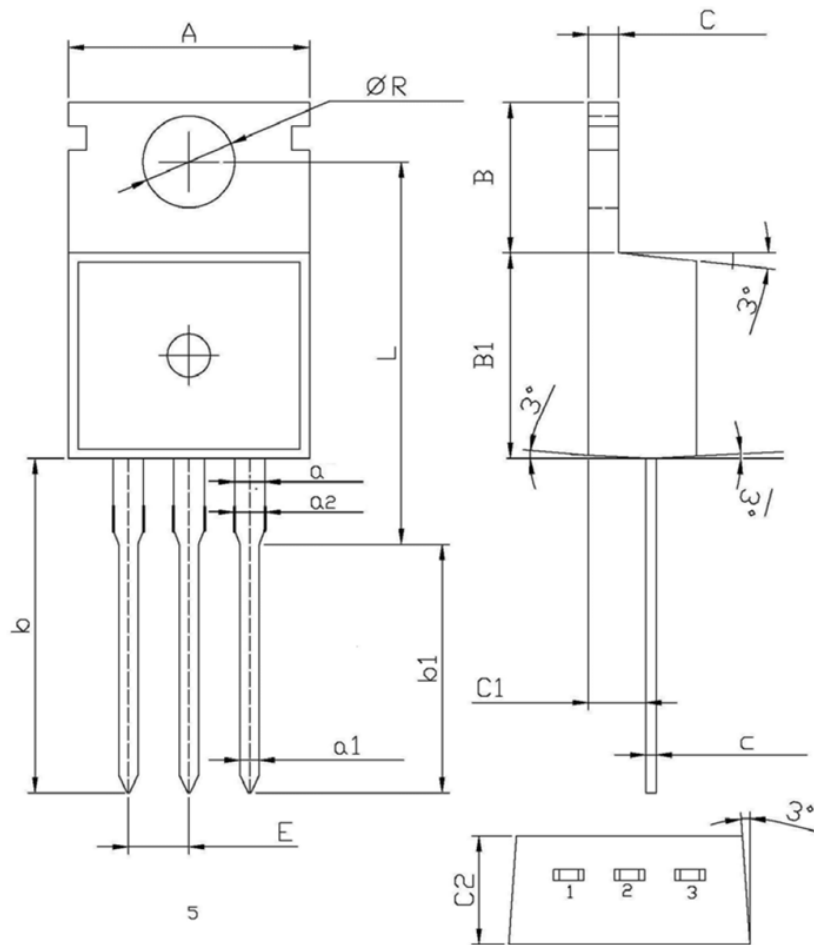

Figure 13: Normalized Maximum Transient Thermal Impedance



Symbol	Dimensions In Millimeters		Dimensions In Inches	
	Min.	Max.	Min.	Max.
A	9.800	10.200	0.386	0.402
R	3.560	3.640	0.140	0.143
L	15.700	16.100	0.618	0.634
b	12.600	13.600	0.496	0.535
b1	9.600	10.600	0.378	0.417
a	1.220	1.320	0.048	0.052
E	2.340	2.740	0.092	0.108
a2	1.250	1.620	0.049	0.064
C	1.200	1.400	0.047	0.055
B	5.900	6.700	0.232	0.264
B1	9.000	9.400	0.354	0.370
C1	2.200	2.600	0.087	0.102
a1	0.700	0.900	0.028	0.035
c	0.400	0.600	0.016	0.024
C2	4.300	4.700	0.169	0.185