

## N-Channel Enhancement Mode MOSFET

500V N-Channel MOSFET

TO-252

### Features

- Low Intrinsic Capacitances.
- Excellent Switching Characteristics.
- Extended Safe Operating Area.
- Unrivalled Gate Charge : $Q_g=13nC$  (Typ.).
- $V_{DSS}=500V, I_D=5A$
- $R_{DS(on)} : 1.56\Omega$  (Max) @ $V_G=10V$
- 100% Avalanche Tested

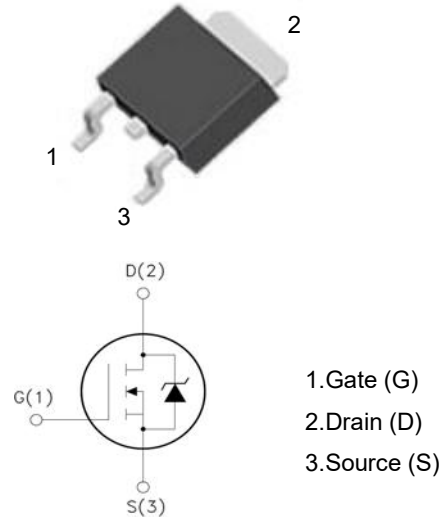

### Absolute Maximum Ratings ( $T_a=25^\circ C$ unless otherwise noted)

Symbol	Parameter	Value	Unit
$V_{DSS}$	Drain-Source Voltage	500	V
$I_D$	Drain Current	$T_j=25^\circ C$	10.0
		$T_j=100^\circ C$	5.7
$V_{GSS}$	Gate-Source Voltage	$\pm 30$	V
$E_{AS}$	Single Pulse Avalanche Energy (note1)	190	mJ
$I_{AR}$	Avalanche Current (note2)	9.0	A
$P_D$	Power Dissipation ( $T_j=25^\circ C$ )	30	W
$T_j$	Junction Temperature(Max)	150	$^\circ C$
$T_{stg}$	Storage Temperature	-55~+150	$^\circ C$
TL	Maximum lead temperature for soldering purpose, 1/8" from case for 5 seconds	300	$^\circ C$

### Thermal Characteristics

Symbol	Parameter	Typ.	Max.	Unit
$R_{\theta JC}$	Thermal Resistance, Junction to Case	-	1.88	$^\circ C/W$
$R_{\theta JA}$	Thermal Resistance, Junction to Ambient	-	62.5	$^\circ C/W$

## Electrical Characteristics (Ta=25°C unless otherwise noted)

Symbol	Parameter	Test Condition	Min.	Typ.	Max.	Unit
<b>Off Characteristics</b>						
$BV_{DSS}$	Drain-Source Breakdown Voltage	$I_D=250\mu A, V_{GS}=0$	500	-	-	V
$\Delta BV_{DSS}/\Delta T_J$	Breakdown Voltage Temperature Coefficient	$I_D=250\mu A$ , Reference to 25°C	-	0.47	-	V/°C
$I_{DSS}$	Zero Gate Voltage Drain Current	$V_{DS}=500V, V_{GS}=0V$	-	-	1	$\mu A$
		$V_{DS}=400V, T_J=125^\circ C$	-	-	10	
$I_{GSSF}$	Gate-body leakage Current, Forward	$V_{GS}=+30V, V_{DS}=0V$	-	-	100	nA
$I_{GSSR}$	Gate-body leakage Current, Reverse	$V_{GS}=-30V, V_{DS}=0V$	-	-	-100	
<b>On Characteristics</b>						
$V_{GS(TH)}$	Date Threshold Voltage	$I_D=250\mu A, V_{DS}=V_{GS}$	2	-	4	V
$R_{DS(ON)}$	Static Drain-Source On-Resistance	$I_D=2.5A, V_{GS}=10V$	-	1.45	1.56	$\Omega$
<b>Dynamic Characteristics</b>						
$C_{iss}$	Input Capacitance	$V_{DS}=25V, V_{GS}=0, f=1.0MHz$	-	620	-	$\mu F$
$C_{oss}$	Output Capacitance		-	70	-	
$C_{rss}$	Reverse Transfer Capacitance		-	8	-	
<b>Switching Characteristics</b>						
$T_d(on)$	Turn-On Delay Time	$V_{DD}=250V, I_D=5A, R_G=25\Omega$ (Note 3,4)	-	13	35	ns
$T_r$	Turn-On Rise Time		-	55	120	
$T_d(off)$	Turn-Off Delay Time		-	25	60	
$T_f$	Turn-Off Rise Time		-	35	80	
$Q_g$	Total Gate Charge	$V_{DS}=400V, V_{GS}=10V, I_D=5A$ (Note 3,4)	-	13	17	nC
$Q_{gs}$	Gate-Source Charge		-	3.4	-	
$Q_{gd}$	Gate-Drain Charge		-	6.4	-	
<b>Drain-Source Diode Characteristics and Maximum Ratings</b>						
$I_S$	Max. Diode Forward Current	-	-	-	5.0	A
$I_{SM}$	Max. Pulsed Forward Current	-	-	-	20	
$V_{SD}$	Diode Forward Voltage	$I_D=5A$	-	-	1.5	V
$T_{rr}$	Reverse Recovery Time	$I_S=5A, V_{GS}=0V$ $diF/dt=100A/\mu s$ (Note3)	-	215	-	nS
$Q_{rr}$	Reverse Recovery Charge		-	1.26	-	$\mu C$

- Notes : 1, L=27mH, IAS=5A, VDD=50V, RG=25 $\Omega$ , Starting T<sub>J</sub> =25°C  
2, Repetitive Rating : Pulse width limited by maximum junction temperature  
3, Pulse Test : Pulse Width  $\leq$  300 $\mu s$ , Duty Cycle  $\leq$  2%  
4, Essentially Independent of Operating Temperature

# Typical Characteristics

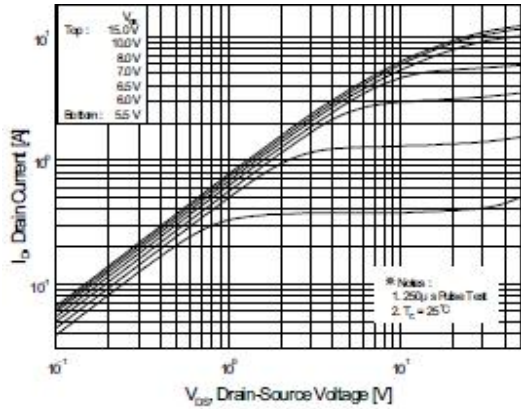

Figure 1. On-Region Characteristics

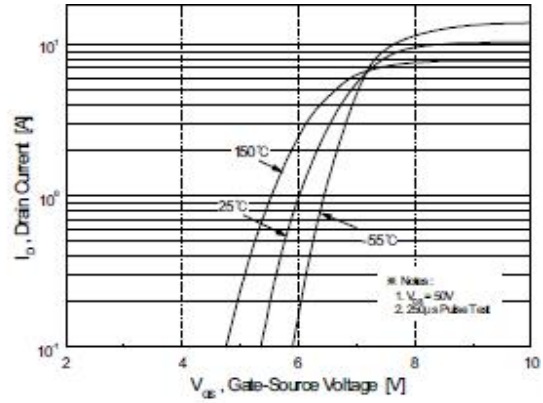

Figure 2. Transfer Characteristics

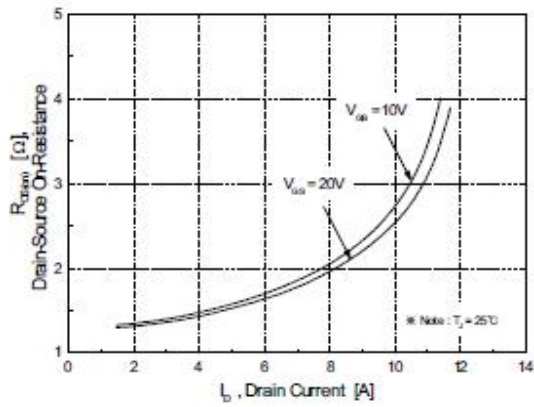

Figure 3. On-Resistance Variation vs. Drain Current and Gate Voltage

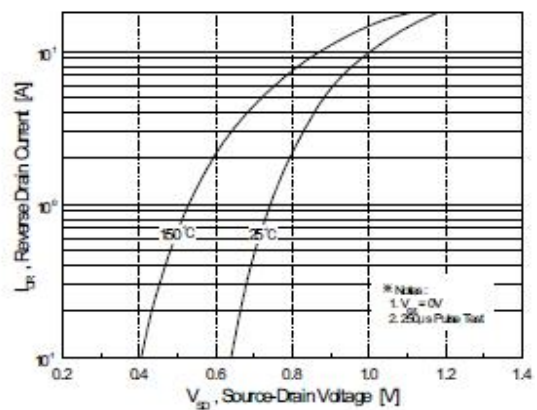

Figure 4. Body Diode Forward Voltage Variation vs. Source Current and Temperature

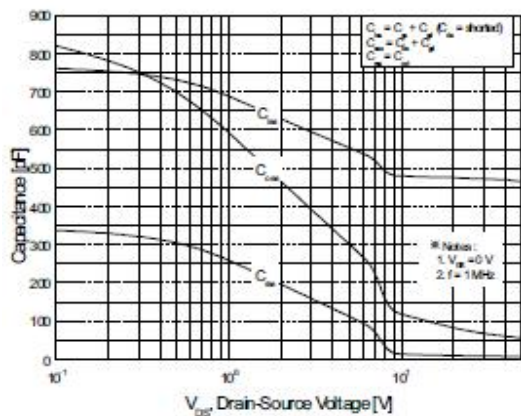

Figure 5. Capacitance Characteristics

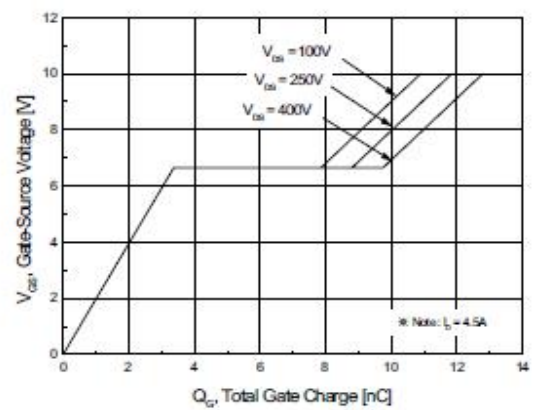

Figure 6. Gate Charge Characteristics

Typical Characteristics (Continued)

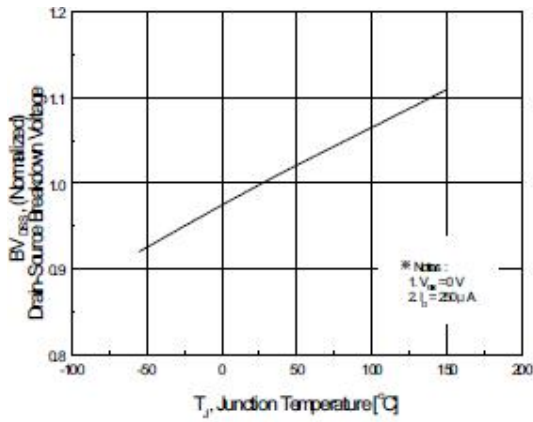

Figure 7. Breakdown Voltage Variation vs. Temperature

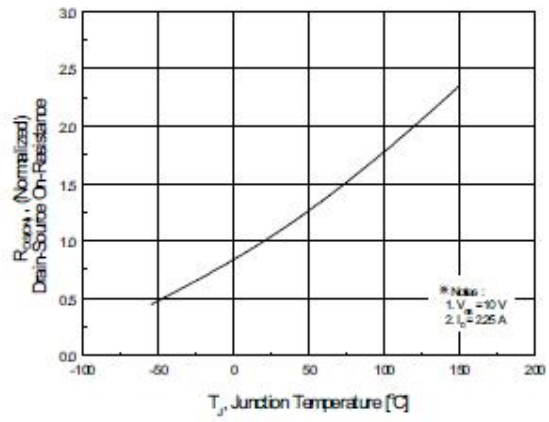

Figure 8. On-Resistance Variation vs. Temperature

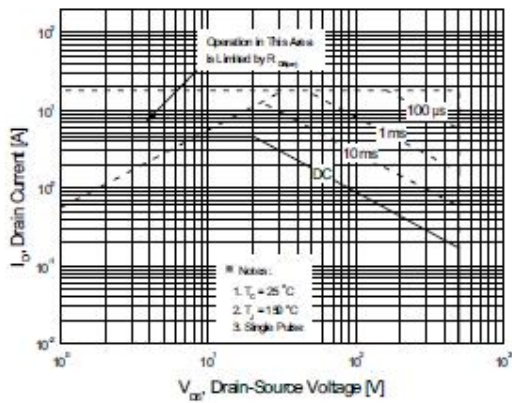

Figure 9. Maximum Safe Operating Area

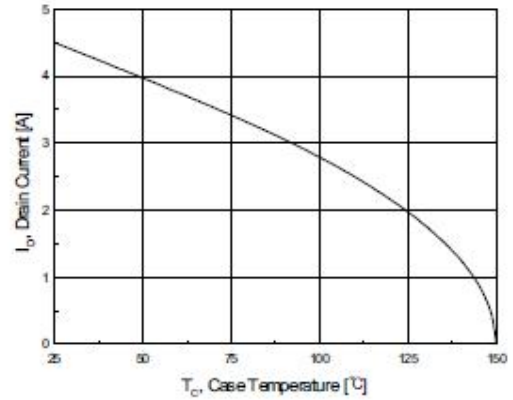

Figure 10. Maximum Drain Current vs. Case Temperature

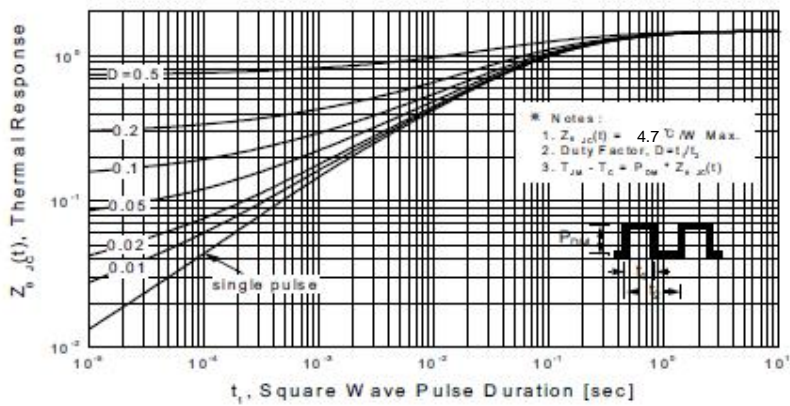
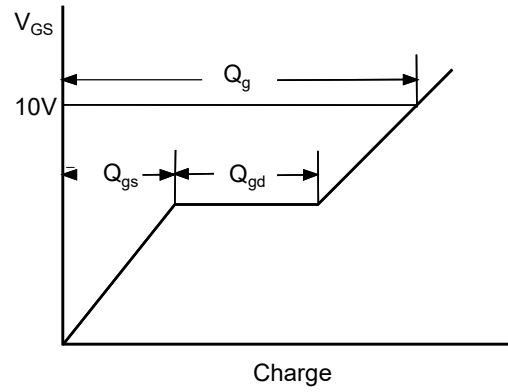
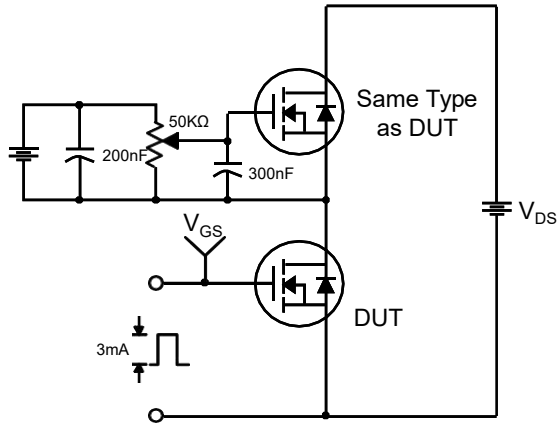
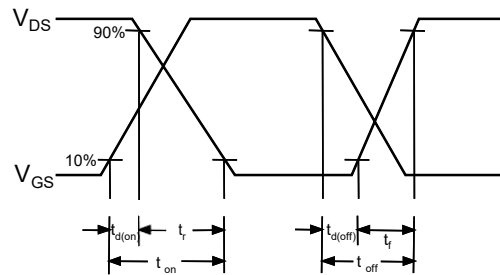
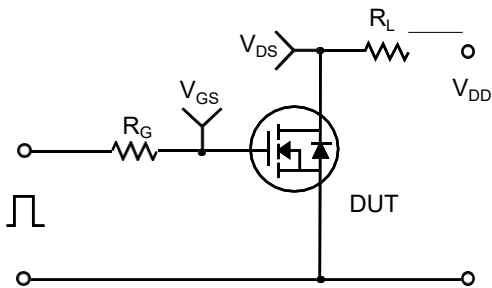

Figure 11. Transient Thermal Response Curve

**Gate Charge Test Circuit & Waveform**



**Resistive Switching Test Circuit & Waveforms**



**Unclamped Inductive Switching Test Circuit & Waveforms**

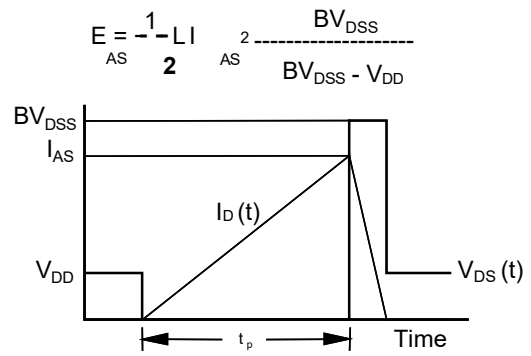
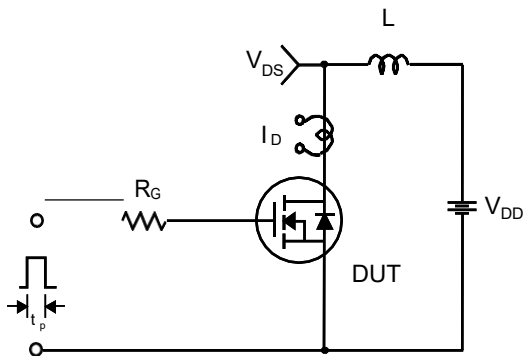

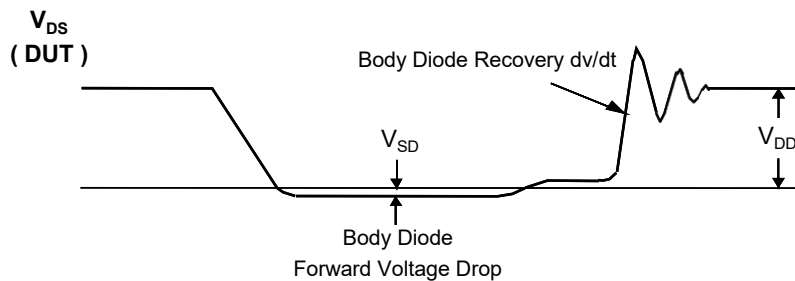
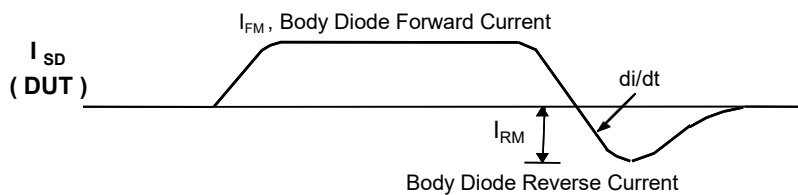
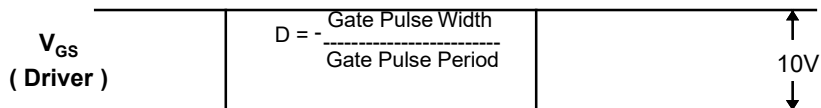
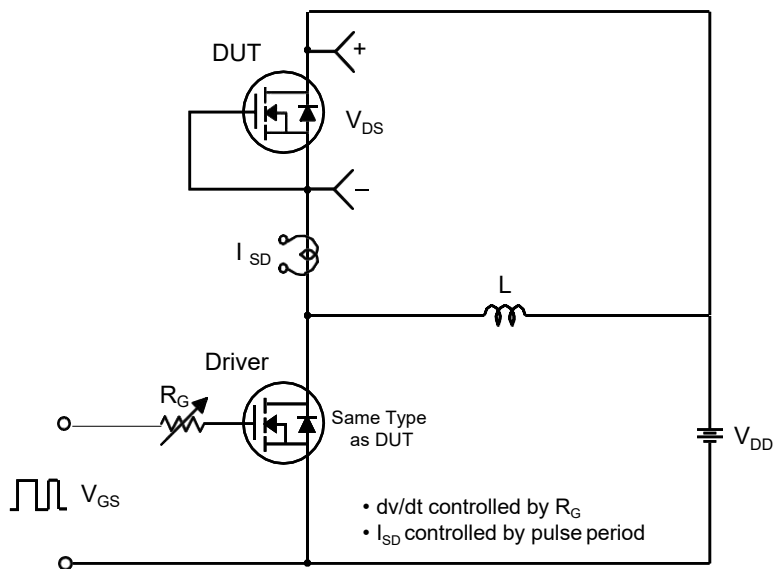

## Package Dimension

T0-252

Unit:mm

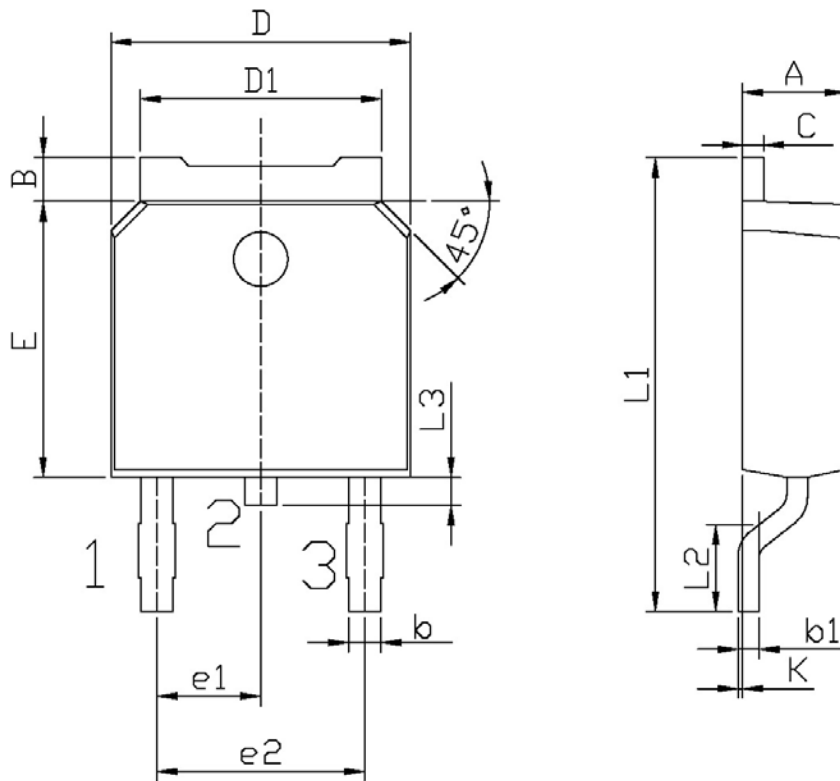

Symbol	Dimensions In Millimeters		Symbol	Dimensions In Millimeters	
	Min	Max		Min	Max
A	2.20	2.40	E	5.95	6.25
B	0.95	1.25	e1	2.24	2.34
b	0.70	0.90	e2	4.43	4.73
b1	0.45	0.55	L1	9.85	10.35
C	0.45	0.55	L2	1.25	1.75
D	6.45	6.75	L3	0.60	0.90
D1	5.20	5.40	K	0.00	0.10