

100V N-Channel MOSFET

Product Summary

$V_{(BR)DSS}$	$R_{DS(on)TYP}$	I_D
100V	4.3mΩ@10V	125A

Feature

- Split Gate Trench Technology
- LOW $R_{DS(ON)}$
- Low Gate Charge
- Low Gate Resistance
- 100% UIS Tested

Application

- Power Switching Application
- DC/DC Converter

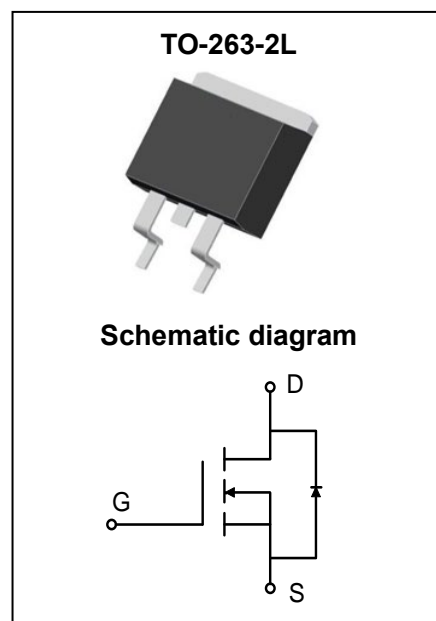

Package Marking and Ordering Information

Part Number	Package	Marking	Packing	Reel Size	Tape Width	Qty
T045N10NTH	TO-263-2L	T045N10N	Reel & Tape	330mm	24mm	800pcs

ABSOLUTE MAXIMUM RATINGS ($T_A = 25^\circ\text{C}$ unless otherwise noted)

Parameter	Symbol	Value	Unit
Drain-Source Voltage	V_{DS}	100	V
Gate-Source Voltage	V_{GS}	±20	V
Continuous Drain Current ¹	$T_C = 25^\circ\text{C}$	I_D	125
	$T_C = 100^\circ\text{C}$	I_D	81
Pulsed Drain Current ²	I_{DM}	500	A
Single Pulsed Avalanche Current ³	I_{AS}	46	A
Single Pulsed Avalanche Energy ³	E_{AS}	530	mJ
Power Dissipation ⁵	$T_C = 25^\circ\text{C}$	P_D	192
Thermal Resistance from Junction to Ambient ⁶	$R_{\theta JA}$	45	$^\circ\text{C/W}$
Thermal Resistance from Junction to Case	$R_{\theta JC}$	0.65	$^\circ\text{C/W}$
Junction Temperature	T_J	150	$^\circ\text{C}$
Storage Temperature	T_{STG}	-55~ +150	$^\circ\text{C}$

Electrical Characteristics ($T_A=25^\circ\text{C}$ unless otherwise noted)

Parameter	Symbol	Test Condition	Min	Type	Max	Unit
Off Characteristics						
Drain-Source Breakdown Voltage	$V_{(BR)DSS}$	$V_{GS} = 0V, I_D = 250\mu A$	100			V
Zero Gate Voltage Drain Current	I_{DSS}	$V_{DS} = 100V, V_{GS} = 0V$			1	μA
Gate-Body Leakage Current	I_{GSS}	$V_{GS} = \pm 20V, V_{DS} = 0V$			± 100	nA
On Characteristics⁴						
Gate Threshold Voltage	$V_{GS(th)}$	$V_{DS} = V_{GS}, I_D = 250\mu A$	2	3	4	V
Drain-Source On-Resistance	$R_{DS(on)}$	$V_{GS} = 10V, I_D = 20A$		4.3	4.8	m Ω
Dynamic Characteristics						
Input Capacitance	C_{iss}	$V_{DS} = 50V, V_{GS} = 0V, f = 0.1MHz$		3986		pF
Output Capacitance	C_{oss}			583		
Reverse Transfer Capacitance	C_{rss}			23		
Gate Resistance	R_g	$V_{DS} = 0V, V_{GS} = 0V, f = 1MHz$		2.0		Ω
Switching Characteristics						
Total Gate Charge	Q_g	$V_{DS} = 50V, V_{GS} = 10V, I_D = 20A$		67.6		nC
Gate-Source Charge	Q_{gs}			17.8		
Gate-Drain Charge	Q_{gd}			17.3		
Turn-On Delay Time	$t_{d(on)}$	$V_{DD} = 50V, V_{GS} = 10V, I_D = 50A,$ $R_G = 3\Omega$		15		ns
Turn-On Rise Time	t_r			20		
Turn-Off Delay Time	$t_{d(off)}$			35		
Turn-Off Fall Time	t_f			15		
Source-Drain Diode Characteristics						
Diode Forward Voltage ⁴	V_{SD}	$V_{GS} = 0V, I_S = 20A$			1.2	V

Notes :

- 1.The maximum current rating is limited by package. And device mounted on a large heatsink.
- 2.Pulse Test : Pulse Width $\leq 10\mu s$, duty cycle $\leq 1\%$.
3. E_{AS} condition: $V_{DD} = 50V, V_{GS} = 10V, L = 0.5mH, R_G = 25\Omega$ Starting $T_J = 25^\circ\text{C}$.
- 4.Pulse Test : Pulse Width $\leq 300\mu s$, duty cycle $\leq 2\%$.
- 5.The power dissipation P_D is limited by $T_{J(MAX)} = 150^\circ\text{C}$. And device mounted on a large heatsink.
- 6.Device mounted on $1in^2$ FR-4 board with 2oz. Copper, in a still air environment with $T_A = 25^\circ\text{C}$.

Typical Characteristics

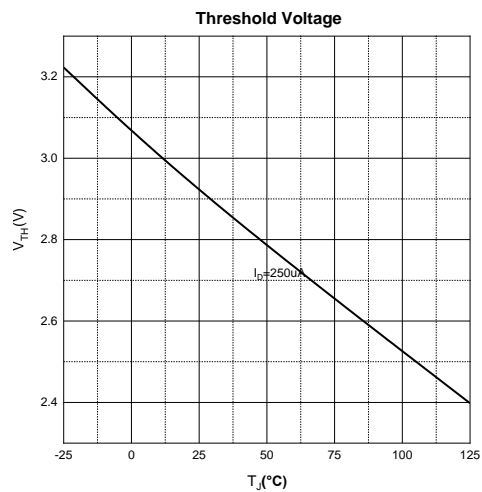
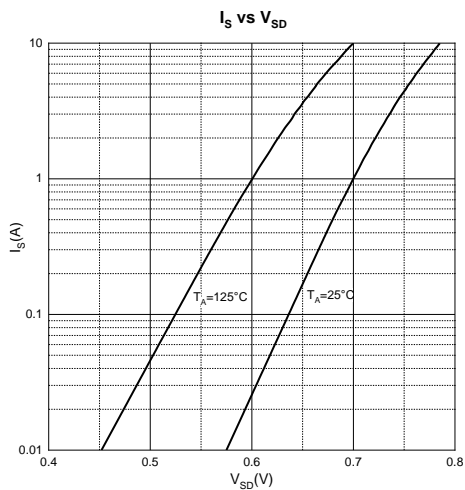
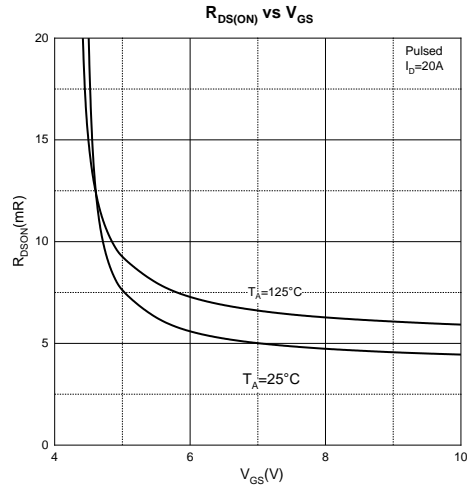
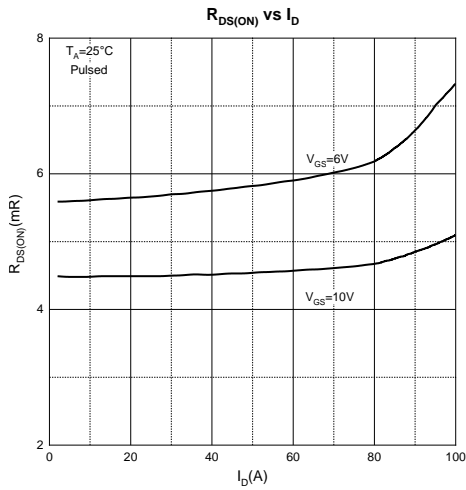
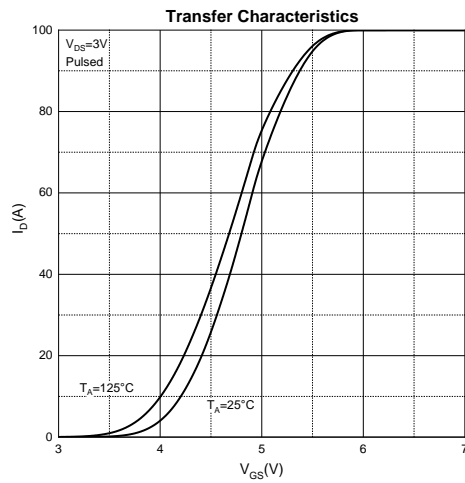
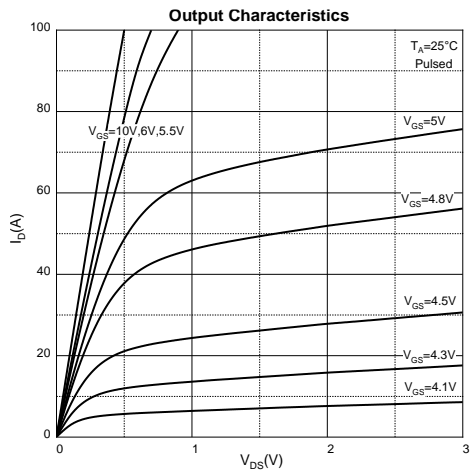

Typical Characteristics

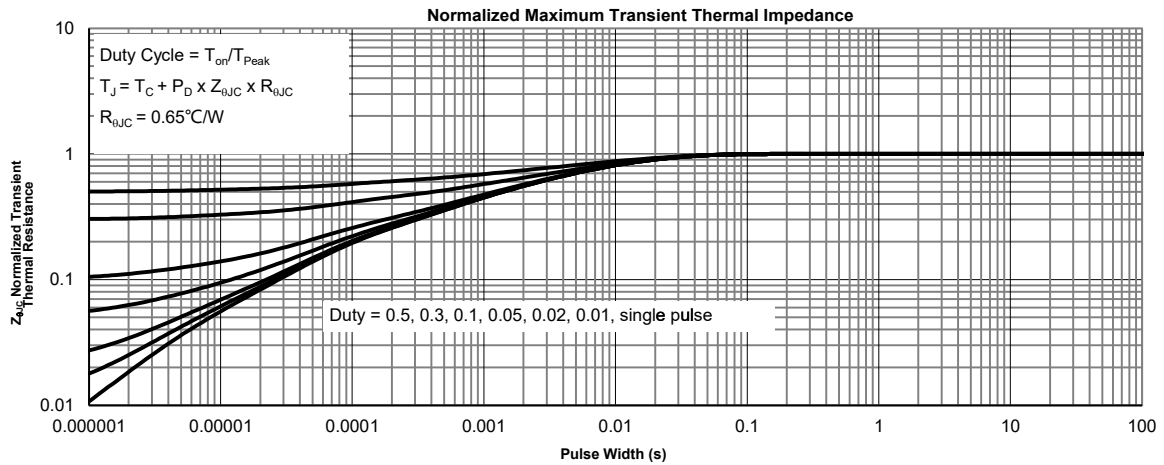
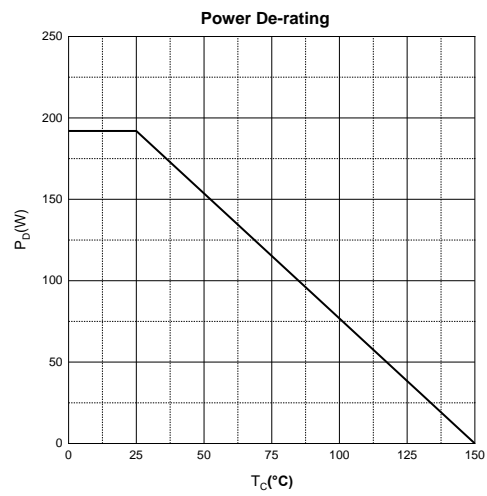
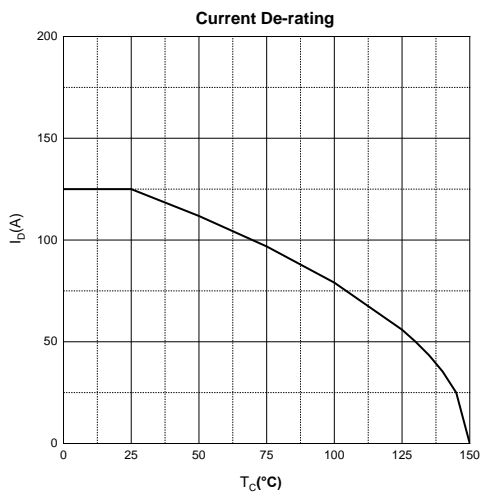
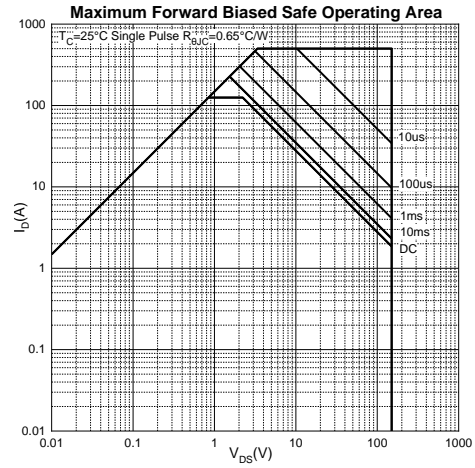
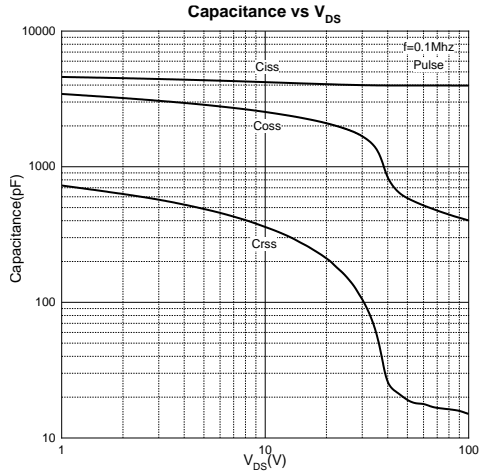

Typical Characteristics

Gate Charge Test Circuit & Waveform

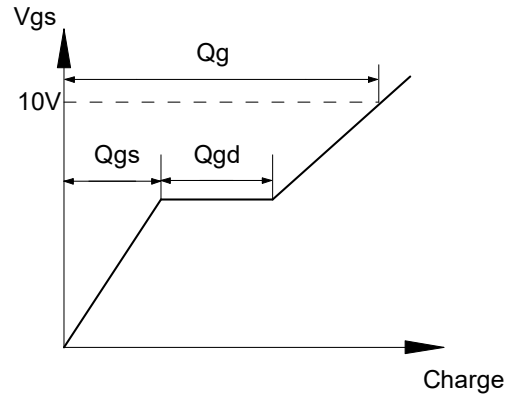
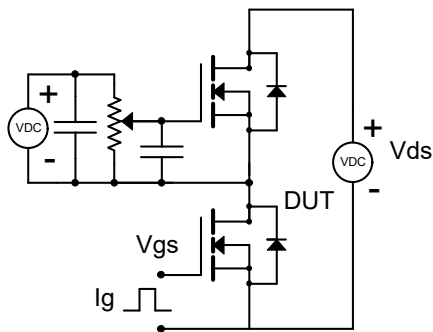

Resistive Switching Test Circuit & Waveform

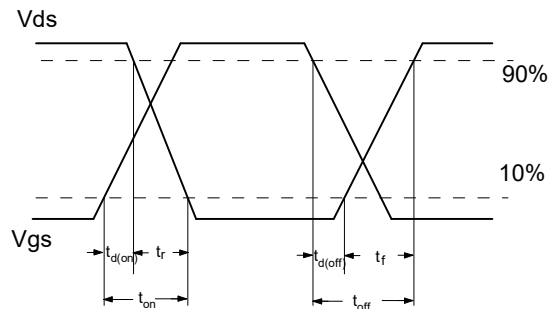
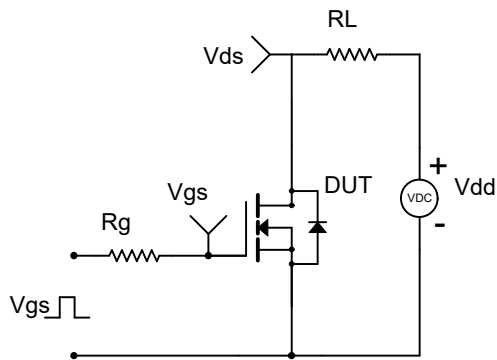

Unclamped Inductive Switching (UIS) Test Circuit & Waveforms

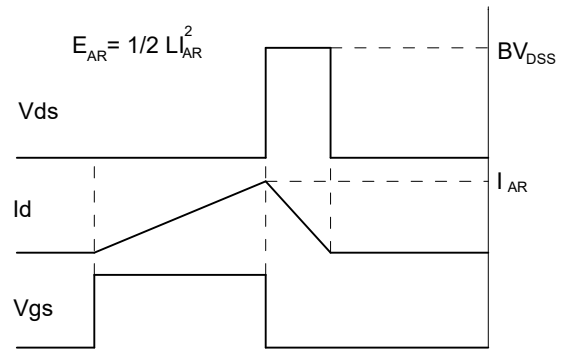
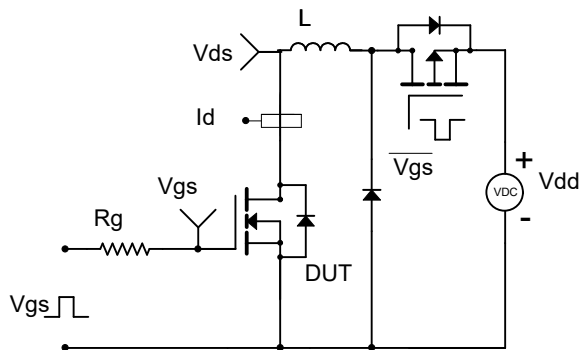

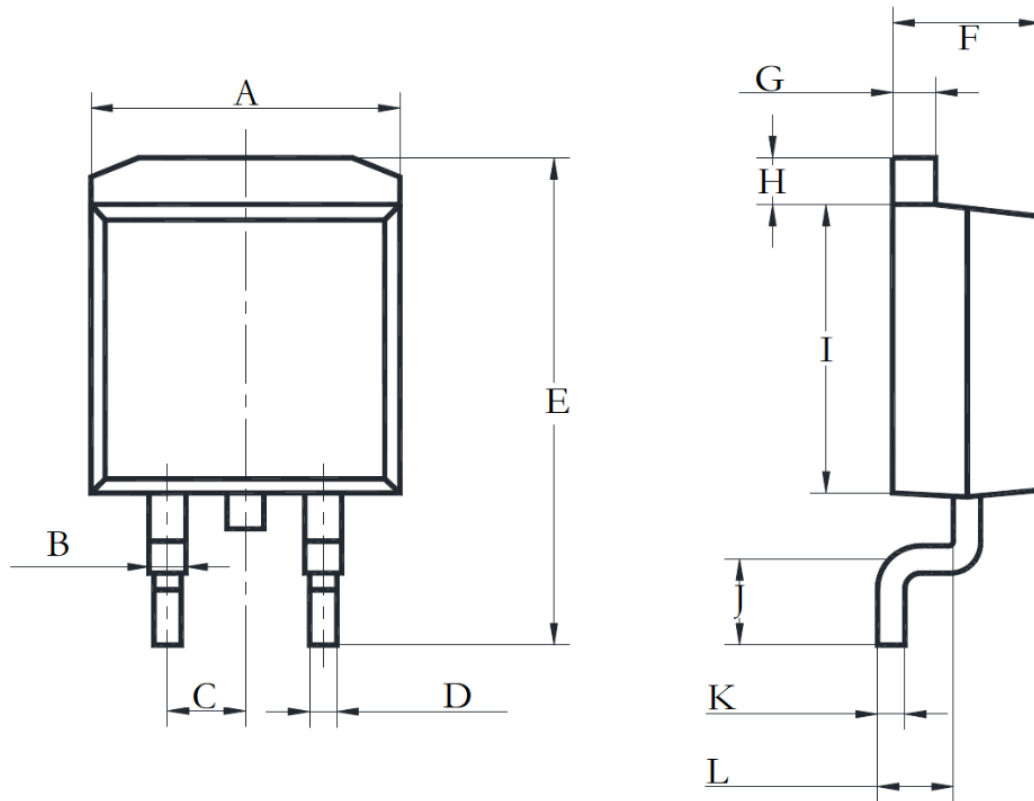

Symbol	Dimensions In Millimeters		Dimensions In Inches	
	Min.	Max.	Min.	Max.
A	9.600	10.500	0.378	0.413
B	1.000	1.400	0.039	0.055
C	2.540REF		0.100REF	
D	0.680	0.940	0.027	0.037
E	14.600	15.880	0.575	0.625
F	4.400	4.800	0.173	0.189
G	1.140	1.400	0.045	0.055
H	1.140	1.400	0.045	0.055
I	8.250	9.650	0.325	0.380
J	2.290	2.790	0.090	0.110
K	0.360	0.650	0.014	0.026
L	2.030	2.790	0.080	0.110