

## 60V Dual N-Channel MOSFET

### Product Summary

$V_{(BR)DSS}$	$R_{DS(on)TYP}$	$I_D$
60V	25mΩ@10V	20A
	32mΩ@4.5V	

### Feature

- Trench Technology Power MOSFET
- Low  $R_{DS(ON)}$
- Low Gate Charge
- Low Gate Resistance
- 100% UIS Tested

### Application

- Power Switching Application

### MARKING:

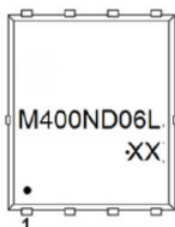

M400ND06L = Device Code  
 XX = Date Code  
 Solid Dot = Green Indicator

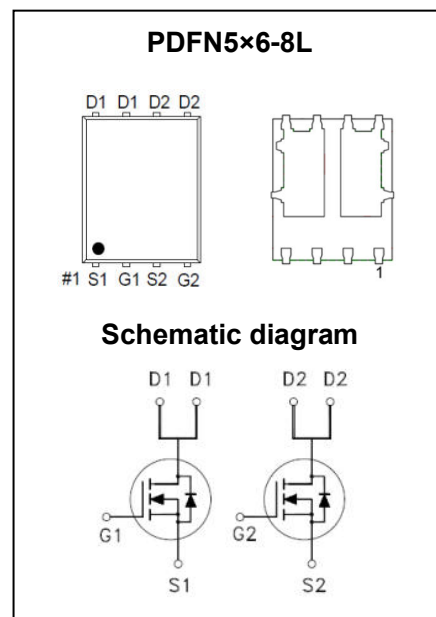

### ABSOLUTE MAXIMUM RATINGS ( $T_A = 25^\circ\text{C}$ unless otherwise noted)

Parameter	Symbol	Value	Unit
Drain - Source Voltage	$V_{DS}$	60	V
Gate - Source Voltage	$V_{GS}$	±20	V
Continuous Drain Current <sup>1</sup>	$T_C = 25^\circ\text{C}$	$I_D$	20
	$T_C = 100^\circ\text{C}$	$I_D$	14
Pulsed Drain Current <sup>2</sup>	$I_{DM}$	80	A
Single Pulsed Avalanche Current <sup>3</sup>	$I_{AS}$	15	A
Single Pulsed Avalanche Energy <sup>3</sup>	$E_{AS}$	56.3	mJ
Power Dissipation <sup>5</sup>	$T_C = 25^\circ\text{C}$	$P_D$	38
Thermal Resistance from Junction to Ambient <sup>6</sup>	$R_{\theta JA}$	63	$^\circ\text{C}/\text{W}$
Thermal Resistance from Junction to Case	$R_{\theta JC}$	3.3	$^\circ\text{C}/\text{W}$
Junction Temperature	$T_J$	150	$^\circ\text{C}$

## Electrical Characteristics ( $T_A=25^\circ\text{C}$ unless otherwise noted)

Parameter	Symbol	Test Condition	Min	Type	Max	Unit
<b>Off Characteristics</b>						
Drain - Source Breakdown Voltage	$V_{(BR)DSS}$	$V_{GS} = 0V, I_D = 250\mu A$	60			V
Zero Gate Voltage Drain Current	$I_{DSS}$	$V_{DS} = 48V, V_{GS} = 0V$			1	$\mu A$
Gate - Body Leakage Current	$I_{GSS}$	$V_{GS} = \pm 20V, V_{DS} = 0V$			$\pm 100$	nA
<b>On Characteristics<sup>4</sup></b>						
Gate Threshold Voltage	$V_{GS(th)}$	$V_{DS} = V_{GS}, I_D = 250\mu A$	1.0	1.6	3.0	V
Drain-source On-resistance	$R_{DS(on)}$	$V_{GS} = 10V, I_D = 5A$		25	40	m $\Omega$
		$V_{GS} = 4.5V, I_D = 5A$		32	50	
<b>Dynamic Characteristics</b>						
Input Capacitance	$C_{iss}$	$V_{DS} = 30V, V_{GS} = 0V, f = 1MHz$		840		pF
Output Capacitance	$C_{oss}$			59		
Reverse Transfer Capacitance	$C_{rss}$			54		
Gate Resistance	$R_g$	$V_{DS} = 0V, V_{GS} = 0V, f = 1MHz$		2.3		$\Omega$
<b>Switching Characteristics</b>						
Total Gate Charge	$Q_g$	$V_{DS} = 30V, V_{GS} = 10V, I_D = 5A$		19		nC
Gate-source Charge	$Q_{gs}$			2.4		
Gate-drain Charge	$Q_{gd}$			2.9		
Turn-on Delay Time	$t_{d(on)}$	$V_{DD} = 30V, V_{GS} = 10V, I_D = 20A$ $R_G = 3\Omega$		5		ns
Turn-on Rise Time	$t_r$			2		
Turn-off Delay Time	$t_{d(off)}$			17		
Turn-off Fall Time	$t_f$			10		
<b>Source - Drain Diode Characteristics</b>						
Diode Forward Voltage <sup>4</sup>	$V_{SD}$	$V_{GS} = 0V, I_S = 10A$			1.2	V

Notes :

- 1.The maximum current rating is limited by package.And device mounted on a large heatsink
- 2.Pulse Test : Pulse Width  $\leq 10\mu s$ , duty cycle  $\leq 1\%$ .
- 3.EAS condition:  $V_{DD} = 30V, V_{GS} = 10V, L = 0.5mH, R_G = 25\Omega$  Starting  $T_J = 25^\circ\text{C}$ .
- 4.Pulse Test : Pulse Width  $\leq 300\mu s$ , duty cycle  $\leq 2\%$ .
- 5.The power dissipation  $P_D$  is limited by  $T_{J(MAX)} = 150^\circ\text{C}$ .And device mounted on a large heatsink
- 6.Device mounted on  $1in^2$  FR-4 board with 2oz. Copper, in a still air environment with  $T_A = 25^\circ\text{C}$ .

# Typical Characteristics

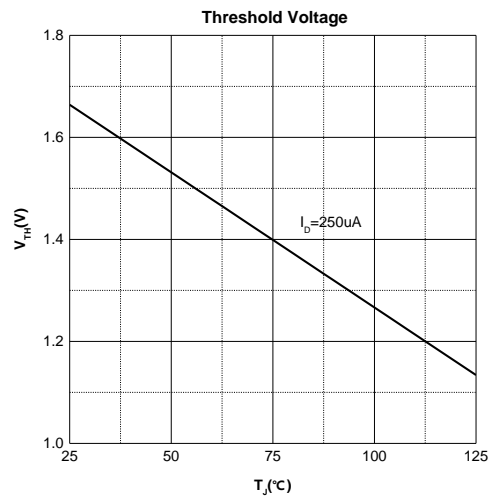
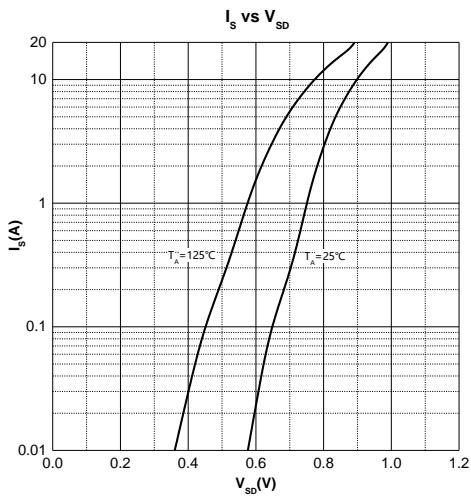
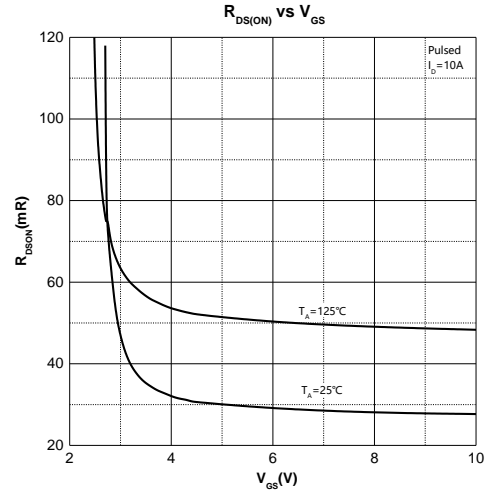
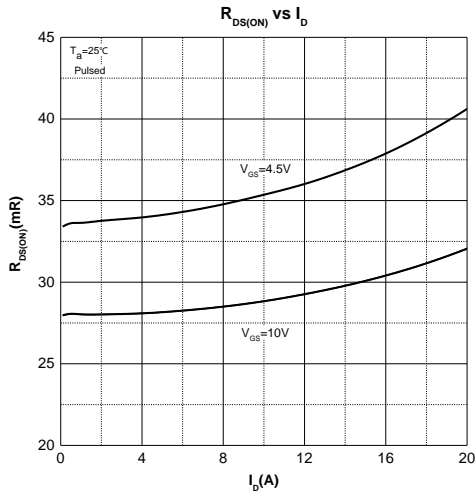
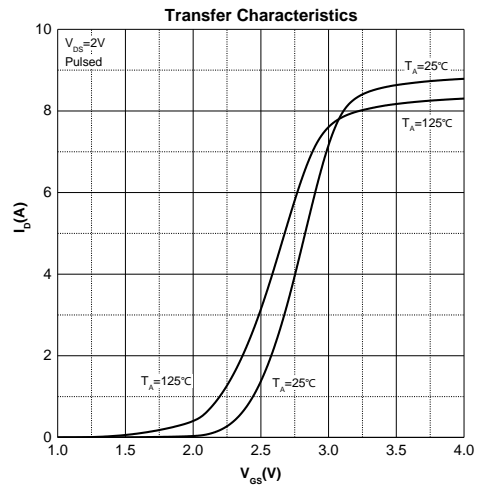
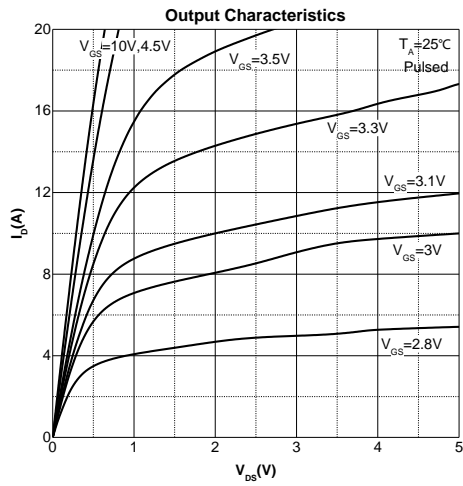

# Typical Characteristics

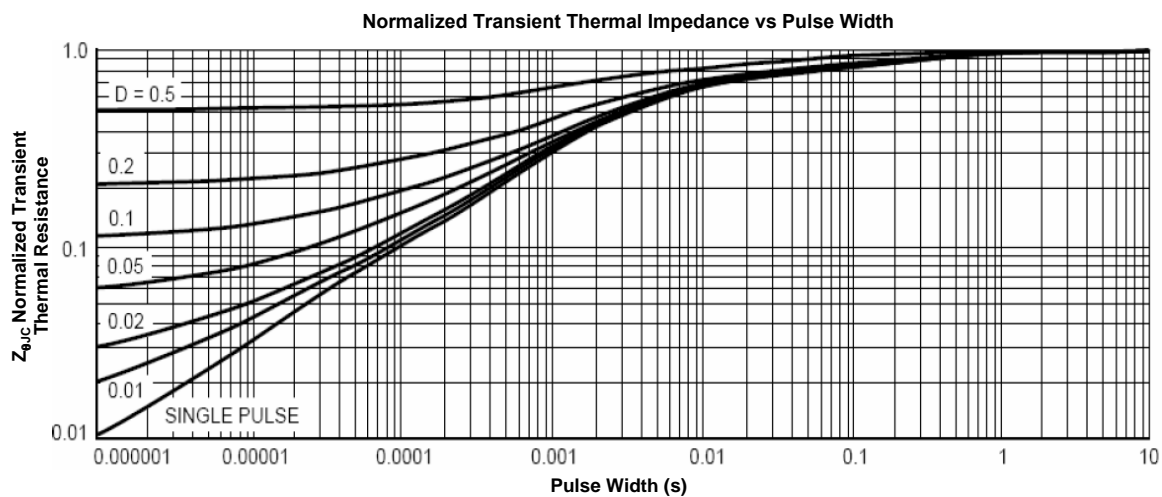
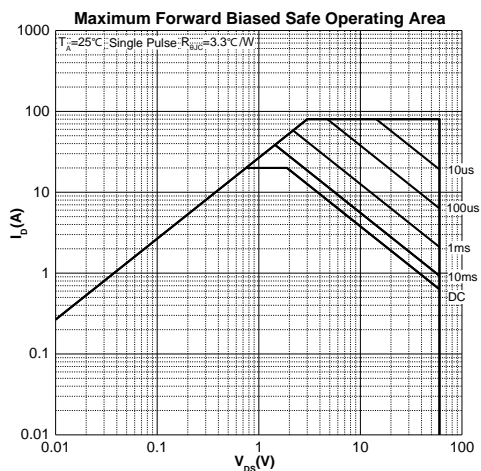
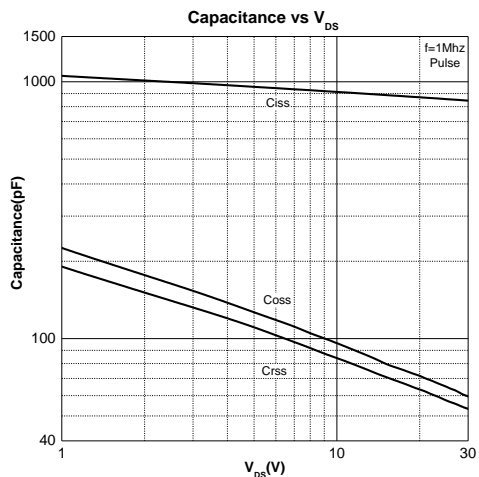

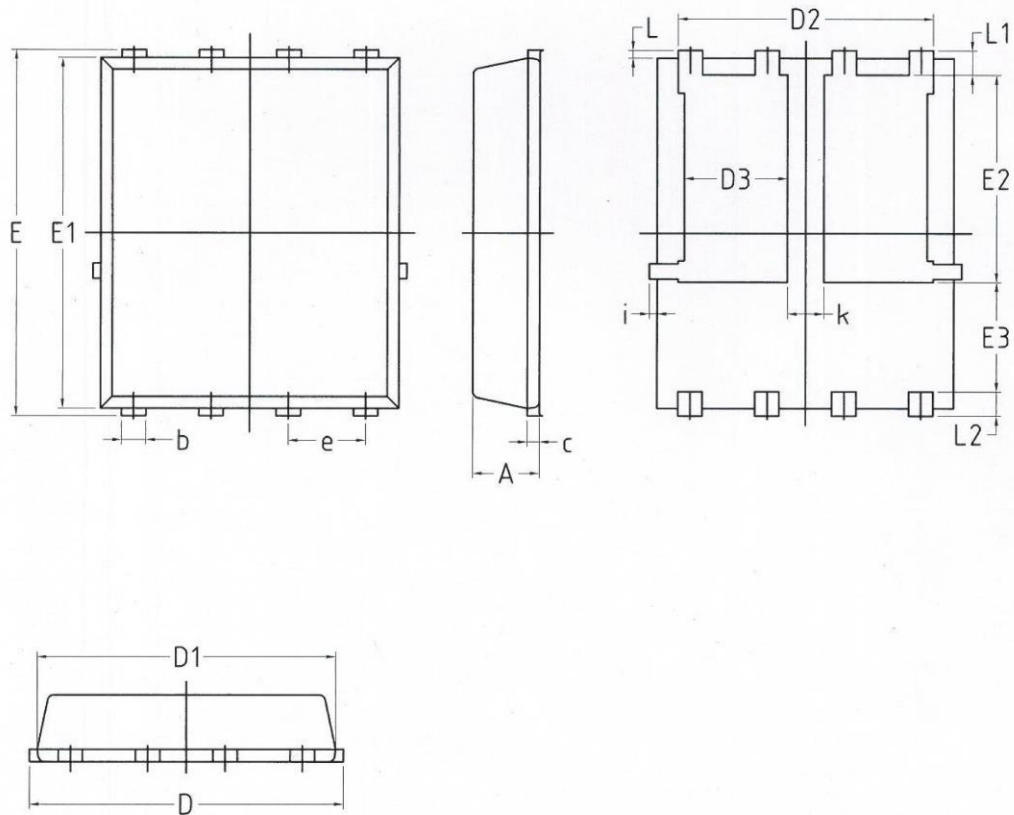

Symbol	Dimensions In Millimeters		Dimensions In Inches	
	Min.	Max.	Min.	Max.
A	1.030	1.170	0.041	0.046
b	0.340	0.480	0.013	0.019
c	0.203 BSC		0.008 BSC	
D	4.800	5.400	0.189	0.213
D1	4.800	5.000	0.189	0.197
D2	4.110	4.310	0.162	0.170
D3	1.600	1.800	0.063	0.071
E	5.950	6.150	0.234	0.242
E1	5.650	5.850	0.222	0.230
E2	3.300	3.500	0.130	0.138
E3	1.700	-	0.067	-
e	1.270 BSC		0.050 BSC	
L	0.050	0.250	0.002	0.010
L1	0.380	0.500	0.015	0.020
L2	0.380	0.500	0.015	0.020
i	-	0.180	-	0.007
k	0.500	0.700	0.020	0.028