

## TO-252-2L Plastic-Encapsulate MOSFET

### 100V N-Channel MOSFET

#### Product Summary

$V_{(BR)DSS}$	$R_{DS(on)TYP}$	$I_D$
100V	25m $\Omega$ @10V	35A
	28m $\Omega$ @4.5V	

#### Feature

- Trench Technology Power MOSFET
- Low  $R_{DS(ON)}$
- Low Gate Charge
- Low Gate Resistance
- 100% UIS Tested

#### Application

- Power Switching Application

#### MARKING:

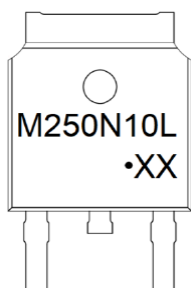

M250N10L = Device Code

XX = Date Code

Solid Dot = Green Indicator

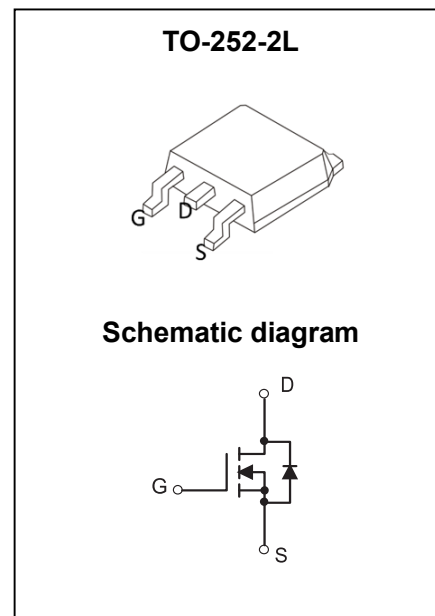

#### ABSOLUTE MAXIMUM RATINGS ( $T_A = 25^\circ\text{C}$ unless otherwise noted)

Parameter	Symbol	Value	Unit
Drain - Source Voltage	$V_{DS}$	100	V
Gate - Source Voltage	$V_{GS}$	$\pm 20$	V
Continuous Drain Current <sup>1</sup>	$I_D$	35	A
$T_C = 25^\circ\text{C}$			
Pulsed Drain Current <sup>2</sup>	$I_{DM}$	120	A
Single Pulsed Avalanche Current <sup>3</sup>	$I_{AS}$	23.4	A
Single Pulsed Avalanche Energy <sup>3</sup>	$E_{AS}$	136.9	mJ
Power Dissipation <sup>5</sup>	$P_D$	83.3	W
$T_C = 25^\circ\text{C}$			
Thermal Resistance from Junction to Ambient <sup>6</sup>	$R_{\theta JA}$	50	$^\circ\text{C/W}$
Thermal Resistance from Junction to Case	$R_{\theta JC}$	1.5	$^\circ\text{C/W}$
Junction Temperature	$T_J$	150	$^\circ\text{C}$
Storage Temperature	$T_{STG}$	-55~ +150	$^\circ\text{C}$

## Electrical Characteristics ( $T_A=25^\circ\text{C}$ unless otherwise noted)

Parameter	Symbol	Test Condition	Min	Type	Max	Unit
<b>Off Characteristics</b>						
Drain - Source Breakdown Voltage	$V_{(BR)DSS}$	$V_{GS} = 0V, I_D = 250\mu A$	100			V
Zero Gate Voltage Drain Current	$I_{DSS}$	$V_{DS} = 100V, V_{GS} = 0V$			1	$\mu A$
Gate - Body Leakage Current	$I_{GSS}$	$V_{GS} = \pm 20V, V_{DS} = 0V$			$\pm 100$	nA
<b>On Characteristics<sup>4</sup></b>						
Gate Threshold Voltage	$V_{GS(th)}$	$V_{DS} = V_{GS}, I_D = 250\mu A$	1.0	1.8	3.0	V
Drain-source On-resistance	$R_{DS(on)}$	$V_{GS} = 10V, I_D = 15A$		25	36	m $\Omega$
		$V_{GS} = 6V, I_D = 10A$		26	42	
		$V_{GS} = 4.5V, I_D = 8A$		28	50	
Forward Transconductance	$g_{FS}$	$V_{DS} = 5V, I_D = 10A$		45		S
<b>Dynamic Characteristics</b>						
Input Capacitance	$C_{iss}$	$V_{DS} = 45V, V_{GS} = 0V, f = 1MHz$		2307		pF
Output Capacitance	$C_{oss}$			90		
Reverse Transfer Capacitance	$C_{rss}$			85		
Gate Resistance	$R_g$	$V_{DS} = 0V, V_{GS} = 0V, f = 1MHz$		4.5		$\Omega$
<b>Switching Characteristics</b>						
Total Gate Charge	$Q_g$	$V_{DS} = 50V, V_{GS} = 10V, I_D = 15A$		59.9		nC
Gate-source Charge	$Q_{gs}$			8.1		
Gate-drain Charge	$Q_{gd}$			3.5		
Turn-on Delay Time	$t_{d(on)}$	$V_{DD} = 50V, V_{GS} = 10V, R_L = 5\Omega$ $R_G = 3\Omega$		7		ns
Turn-on Rise Time	$t_r$			7		
Turn-off Delay Time	$t_{d(off)}$			29		
Turn-off Fall Time	$t_f$			7		
<b>Source - Drain Diode Characteristics</b>						
Diode Forward Voltage <sup>4</sup>	$V_{SD}$	$V_{GS} = 0V, I_S = 15A$			1.2	V

Notes :

- 1.The maximum current rating is limited by package.And device mounted on a large heatsink
- 2.Pulse Test : Pulse Width  $\leq 10\mu s$ , duty cycle  $\leq 1\%$ .
3. $E_{AS}$  condition:  $V_{DD} = 50V, V_{GS} = 10V, L = 0.5mH, R_G = 25\Omega$  Starting  $T_J = 25^\circ\text{C}$ .
- 4.Pulse Test : Pulse Width  $\leq 300\mu s$ , duty cycle  $\leq 2\%$ .
- 5.The power dissipation  $P_D$  is limited by  $T_{J(MAX)} = 150^\circ\text{C}$ .And device mounted on a large heatsink
- 6.Device mounted on  $1in^2$  FR-4 board with 2oz. Copper, in a still air environment with  $T_A = 25^\circ\text{C}$ .

# Typical Characteristics

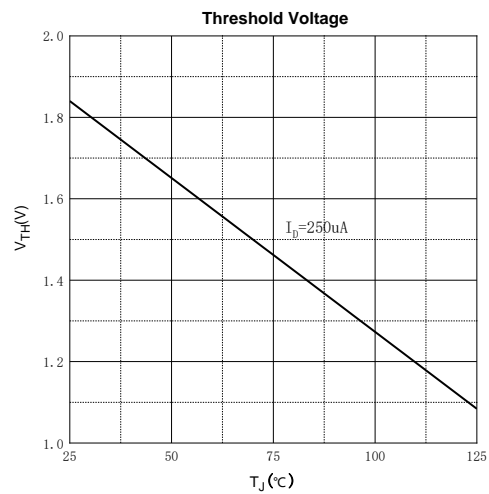
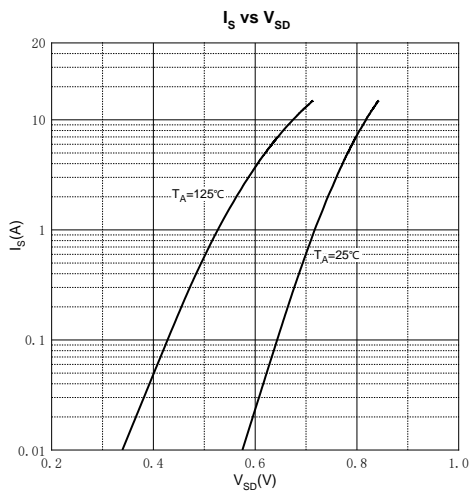
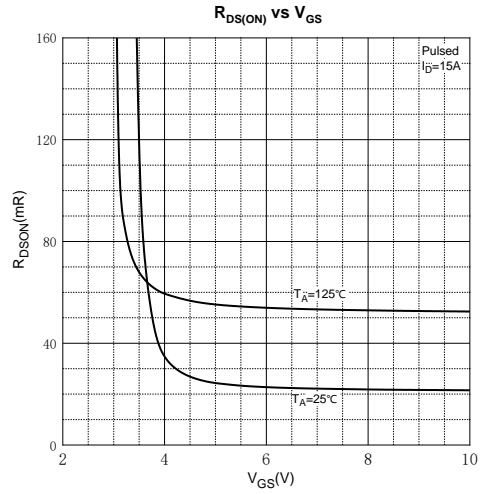
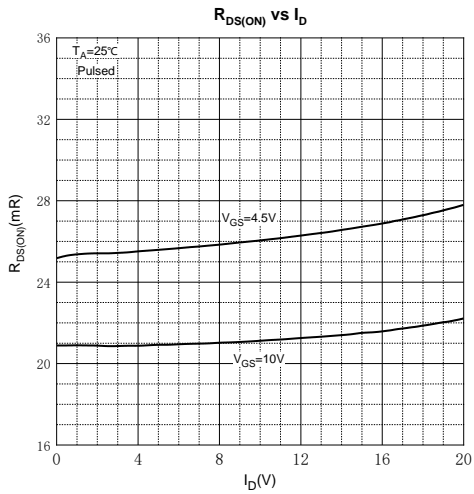
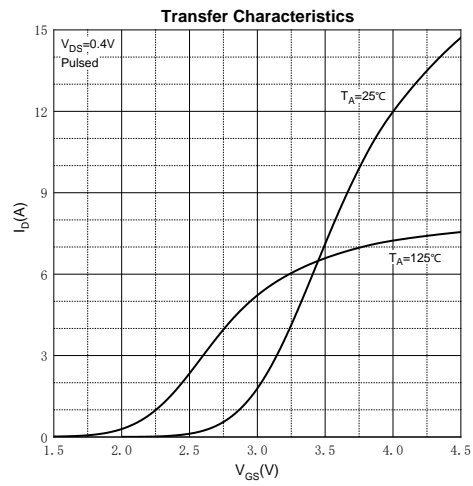
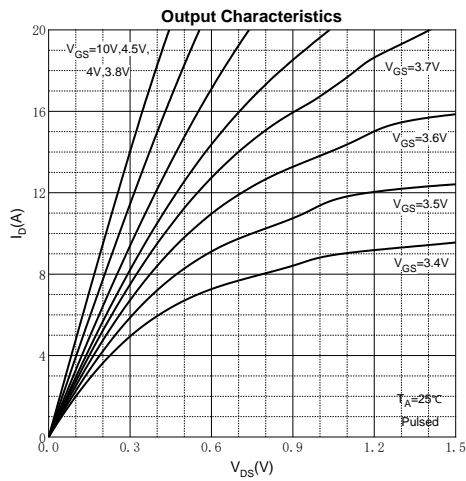

# Typical Characteristics

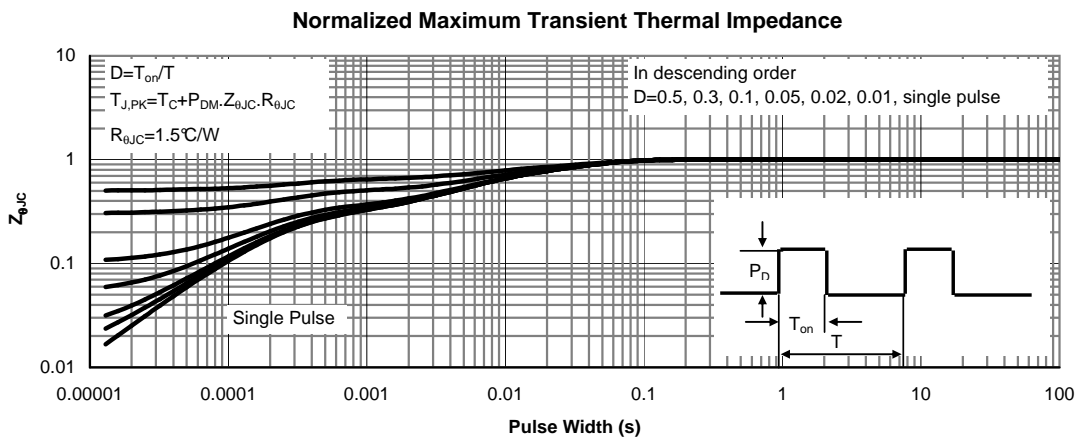
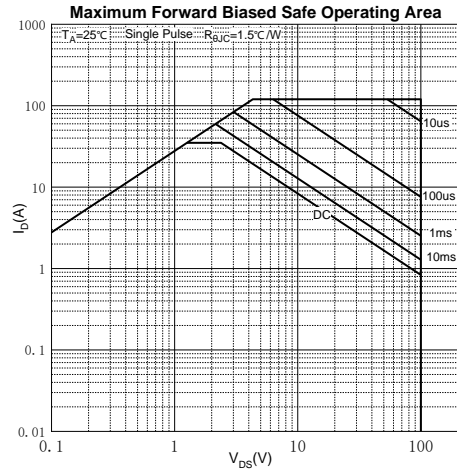
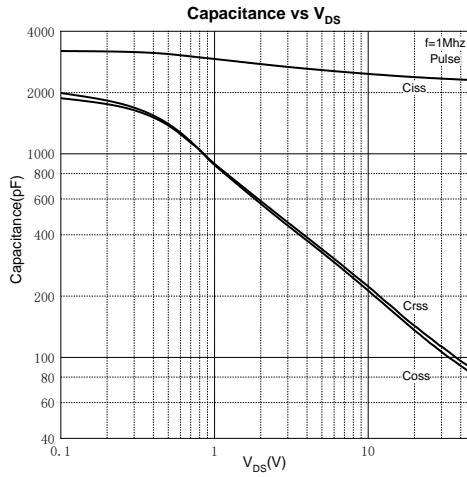

# TO-252-2L Package Outline Dimensions

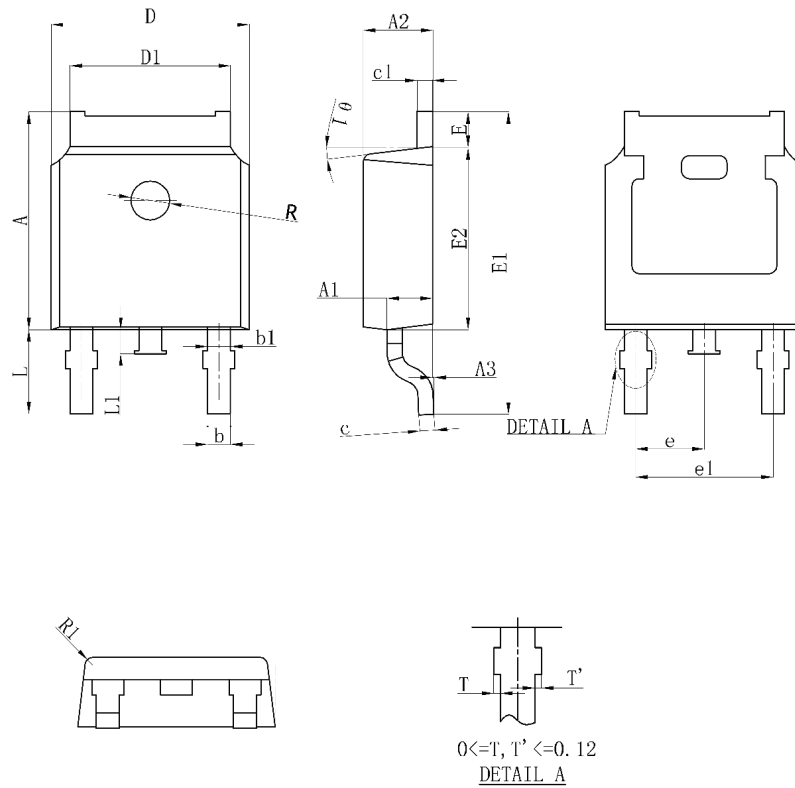

Symbol	Dimensions In Millimeters		Dimensions In Inches	
	Min.	Max.	Min.	Max.
A	6.850	7.250	0.269	0.285
A1	0.960	1.060	0.038	0.042
A2	2.200	2.400	0.087	0.094
A3	0.000	0.127	0.000	0.005
b	0.760REF		0.030REF	
b1	1.000REF		0.039REF	
c	0.508REF		0.020REF	
c1	0.508REF		0.020REF	
D	6.250	6.850	0.246	0.270
D1	5.050	5.650	0.199	0.222
E	0.850	1.050	0.033	0.041
E1	9.700	10.400	0.382	0.409
E2	5.800	6.400	0.228	0.252
e	2.286BSC		0.090BSC	
e1	4.572REF		0.180REF	
L	2.650	2.950	0.104	0.116
L1	0.600	0.900	0.024	0.035
$\theta$	7°REF		7°REF	
R	1.300REF		0.051REF	
R1	0.250REF		0.010REF	

### NOTICE

JSHD reserve the right to make modifications, enhancements, improvements, corrections or other changes without further notice to any product herein. JSHD does not assume any liability arising out of the application or use of any product described herein.