

## SMBG Plastic-Encapsulate Diodes

### Zener Diodes

#### Features

- $P_d$  3.0W
- $V_z$  3.3V-200V
- Range 5%

#### Applications

- Stabilizing Voltage

#### Mechanical Data

- Case: JEDEC DO-214AA molded plastic
- Molding compound: UL flammability classification rating 94V-0
- Terminals: Solder plated, solderable per MIL-STD-202, Method 208
- Polarity: Color band denotes cathode end

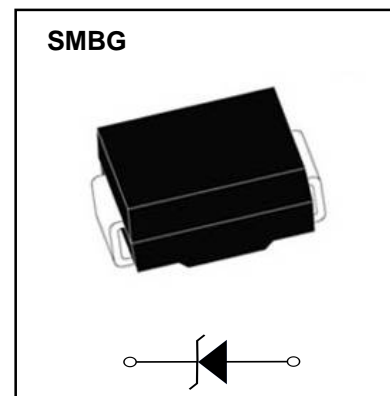

#### Limiting Values (Absolute Maximum Rating)

Item	Symbol	Unit	Conditions	Max
Power dissipation	$P_d$	W	$T_L=75^\circ\text{C}$	3.0
Zener current	$I_z$	mA		$P_v / V_z$
Maximum junction temperature	$T_j$	$^\circ\text{C}$		-65 to +150
Storage temperature range	$T_{stg}$	$^\circ\text{C}$		-65 to +150

#### Electrical Characteristics ( $T_a=25^\circ\text{C}$ Unless otherwise specified)

Item	Symbol	Unit	Conditions	Max
Thermal resistance	$R_{\theta JA}$	$^\circ\text{C}/\text{W}$	Between junction to ambient	226
	$R_{\theta JL}$	$^\circ\text{C}/\text{W}$	Between junction to lead	25
Forward voltage	$V_F$	V	$I_F=200\text{mA}$	1.5

## Electrical Characteristics ( $T_A=25^\circ\text{C}$ unless otherwise noted)

Device (Note 2)	Zener Voltage (Note 3)			Zener Impedance (Note 4)			Leakage Current		$I_{ZM}$ mA(dc)	
	$V_Z$ (Volts)			@ $I_{ZT}$	$Z_{ZT}$ @ $I_{ZT}$	$Z_{ZK}$ @ $I_{ZK}$	$I_R$ @ $V_R$			
	Min	Nom	Max	mA	$\Omega$	$\Omega$	mA	$\mu\text{A}$		Volts
1SMB5913B	3.13	3.3	3.47	113.6	10	500	1	100	1	454
1SMB5914B	3.42	3.6	3.78	104.2	9	500	1	75	1	416
1SMB5915B	3.70	3.9	4.10	96.1	7.5	500	1	25	1	384
1SMB5916B	4.08	4.3	4.52	87.2	6	500	1	5	1	348
1SMB5917B	4.46	4.7	4.94	79.8	5	500	1	5	1.5	319
1SMB5918B	4.84	5.1	5.36	73.5	4	350	1	5	2	294
1SMB5919B	5.32	5.6	5.88	66.9	2	250	1	5	3	267
1SMB5920B	5.89	6.2	6.51	60.5	2	200	1	5	4	241
1SMB5921B	6.46	6.8	7.14	55.1	2.5	200	1	5	5.2	220
1SMB5922B	7.12	7.5	7.88	50	3	400	0.5	5	6	200
1SMB5923B	7.79	8.2	8.61	45.7	3.5	400	0.5	5	6.5	182
1SMB5924B	8.64	9.1	9.56	41.2	4	500	0.5	5	7	164
1SMB5925B	9.5	10	10.5	37.5	4.5	500	0.25	5	8	150
1SMB5926B	10.45	11	11.55	34.1	5.5	550	0.25	1	8.4	136
1SMB5927B	11.4	12	12.6	31.2	6.5	550	0.25	1	9.1	125
1SMB5928B	12.35	13	13.65	28.8	7	550	0.25	1	9.9	115
1SMB5929B	14.25	15	15.75	25	9	600	0.25	1	11.4	100
1SMB5930B	15.2	16	16.8	23.4	10	600	0.25	1	12.2	93
1SMB5931B	17.1	18	18.9	20.8	12	650	0.25	1	13.7	83
1SMB5932B	19	20	21	18.7	14	650	0.25	1	15.2	75
1SMB5933B	20.9	22	23.1	17	17.5	650	0.25	1	16.7	68
1SMB5934B	22.8	24	25.2	15.6	19	700	0.25	1	18.2	62
1SMB5935B	25.65	27	28.35	13.9	23	700	0.25	1	20.6	55
1SMB5936B	28.5	30	31.5	12.5	28	750	0.25	1	22.8	50
1SMB5937B	31.35	33	34.65	11.4	33	800	0.25	1	25.1	45
1SMB5938B	34.2	36	37.8	10.4	38	850	0.25	1	27.4	41
1SMB5939B	37.05	39	40.95	9.6	45	900	0.25	1	29.7	38
1SMB5940B	40.85	43	45.15	8.7	53	950	0.25	1	32.7	34
1SMB5941B	44.65	47	49.35	8	67	1000	0.25	1	35.8	31
1SMB5942B	48.45	51	53.55	7.3	70	1100	0.25	1	38.8	29
1SMB5943B	53.2	56	58.8	6.7	86	1300	0.25	1	42.6	26
1SMB5944B	58.9	62	65.1	6	100	1500	0.25	1	47.1	24
1SMB5945B	64.6	68	71.4	5.5	120	1700	0.25	1	51.7	22
1SMB5946B	71.25	75	78.75	5	140	2000	0.25	1	56	20
1SMB5947B	77.9	82	86.1	4.6	160	2500	0.25	1	62.2	18
1SMB5948B	86.45	91	95.55	4.1	200	3000	0.25	1	69.2	16
1SMB5949B	95	100	105	3.7	250	3100	0.25	1	76	15
1SMB5950B	104.5	110	115.5	3.4	300	4000	0.25	1	83.6	13
1SMB5951B	114	120	126	3.1	380	4500	0.25	1	91.2	12
1SMB5952B	123.5	130	136.5	2.9	450	5000	0.25	1	98.8	11
1SMB5953B	142.5	150	157.5	2.5	600	6000	0.25	1	114	10
1SMB5954B	152	160	168	2.3	700	6500	0.25	1	121.6	9
1SMB5955B	171	180	189	2.1	900	7000	0.25	1	136.8	8
1SMB5956B	190	200	210	1.9	1200	8000	0.25	1	152	7

2. **TOLERANCE AND TYPE NUMBER DESIGNATION** The type numbers listed indicate a tolerance of  $\pm 5\%$ .

3. **ZENER VOLTAGE ( $V_Z$ ) MEASUREMENT**

Nominal Zener voltage is measured with the device junction in thermal equilibrium with ambient temperature at  $25^\circ\text{C}$ .

4. **ZENER IMPEDANCE ( $Z_Z$ ) DERIVATION**  $Z_{ZT}$  and  $Z_{ZK}$  are measured by dividing the ac voltage drop across the device by the ac current applied. The specified limits are for  $I_{Z(ac)} = 0.1 I_{Z(dc)}$  with the ac frequency = 60 Hz.

# Typical Characteristics

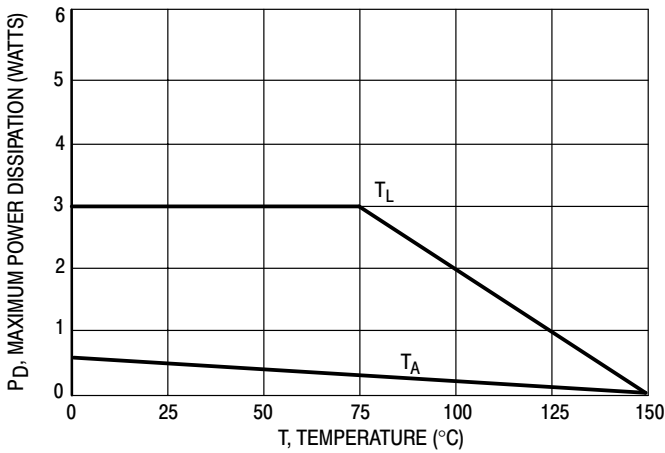

Figure 1. Steady State Power Derating

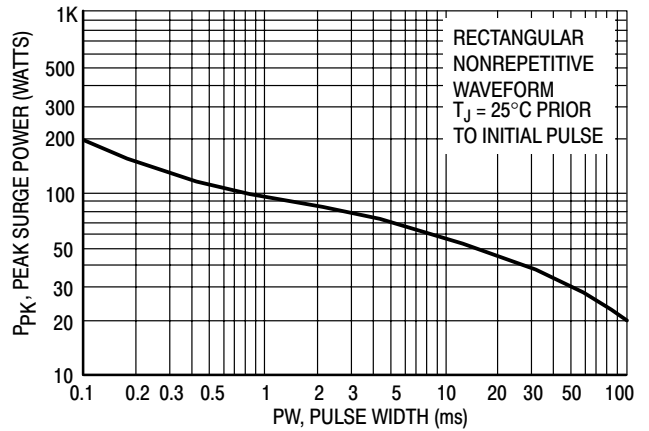

Figure 2. Maximum Surge Power

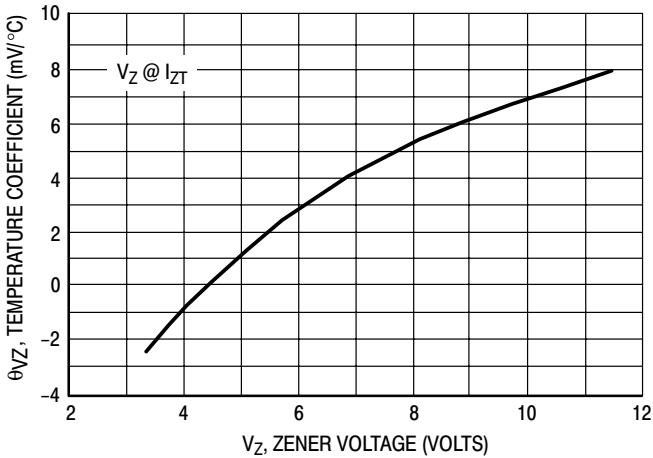

Figure 3. Zener Voltage - To 12 Volts

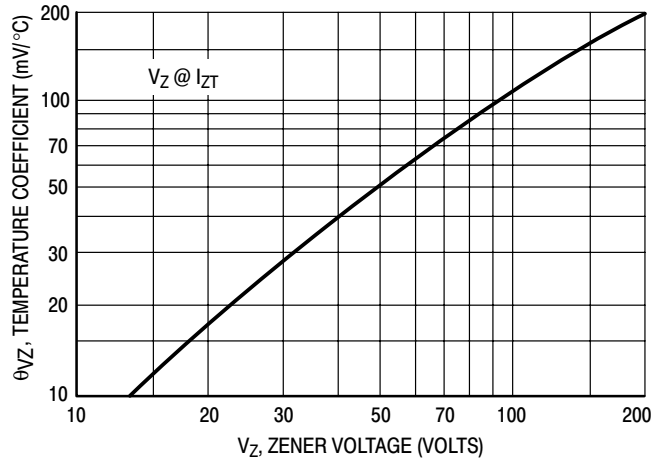

Figure 4. Zener Voltage - 14 To 200 Volts

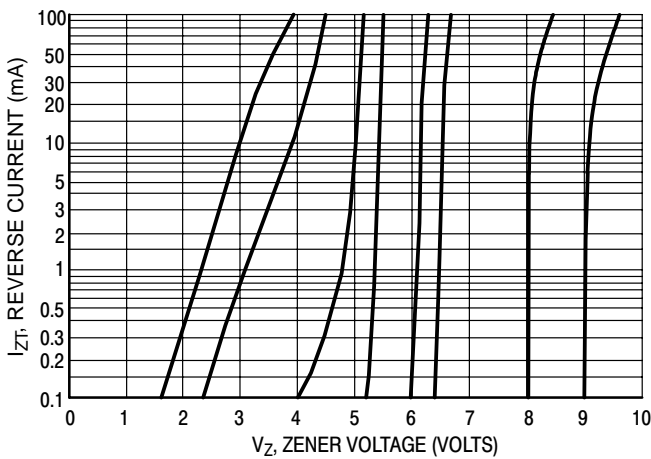

Figure 5. V<sub>Z</sub> = 3.3 thru 10 Volts

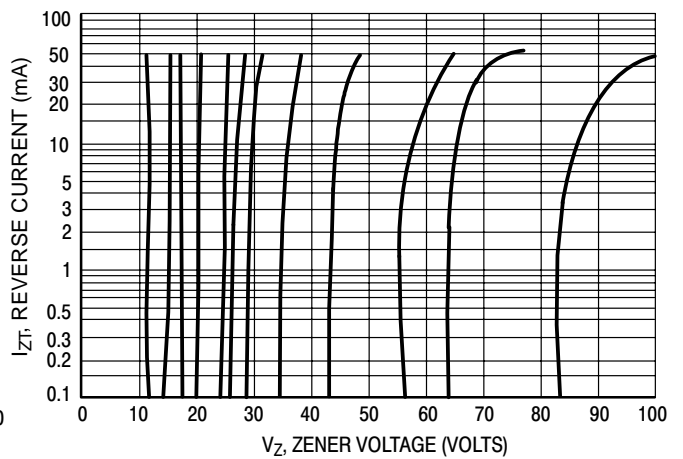
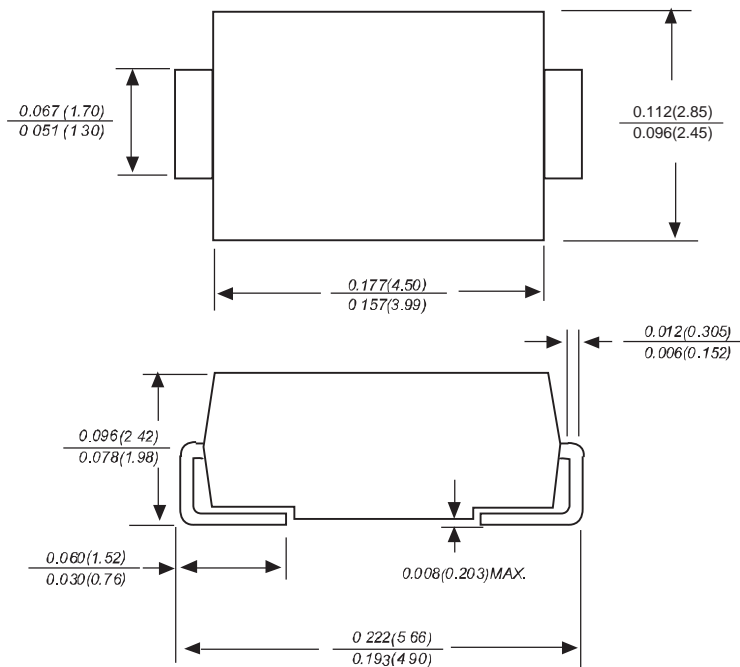

Figure 6. V<sub>Z</sub> = 12 thru 82 Volts

## SMBG Package Outline Dimensions



Dimensions in inches and (millimeters)

## SMBG Suggested Pad Layout

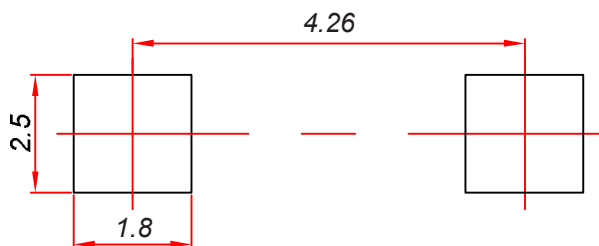

### Note:

1. Controlling dimension: in millimeters.
2. General tolerance:  $\pm 0.05\text{mm}$ .
3. The pad layout is for reference purposes only.

## Ordering Information

Part Number	Package	Shipping Quantity
1SMB5913B -1SMB5956B	SMBG	3000/tape&Reel

## Marking Diagram

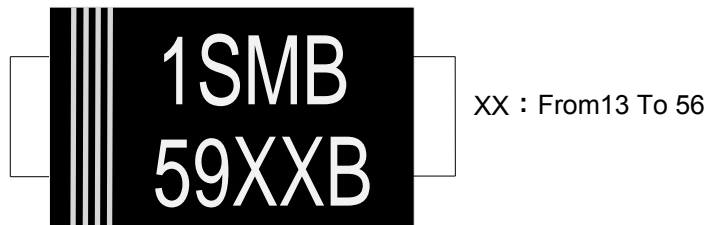

# Reel Taping Specifications For Surface Mount Devices-SMBG

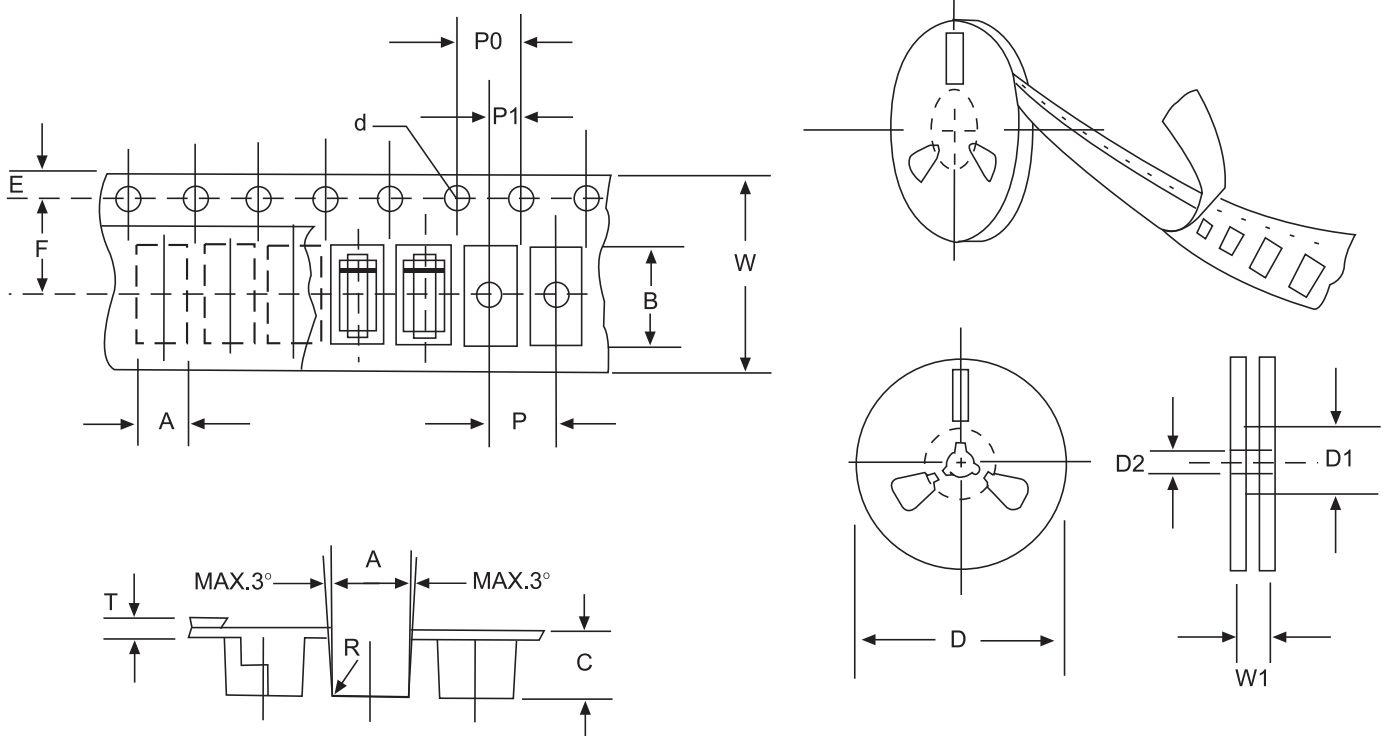

**FIG : CONFIGURATION OF SURFACE MOUNTED DEVICES TAPING**

ITEM	SYMBOL	SMBG mm(inch)
Carrier width	A	4.09±0.1(0.161±0.004)
Carrier length	B	5.82±0.1(0.229±0.004)
Carrier depth	C	2.50±0.1(0.100±0.004)
Sprocket hole	d	1.55±0.05(0.061±0.002)
Reel outside diameter	D	330±2.0(13±0.079)
Reel inner diameter	D1	75±1.0 ( 2.95 ±0.039)
Feed hole diameter	D2	13±0.5(0.512±0.020)
Stroket hole position	E	1.75±0.1(0.069±0.004)
Punch hole position	F	5.65±0.05(0.222±0.002)
Punch hole pitch	P	8.0±0.1(0.315±0.004)
Sprocket hole pitch	P0	4.0±0.1(0.157±0.004)
Embossment center	P1	2.0±0.1(0.079±0.004)
Totall tape thickness	T	0.32±0,1(0.013±0.004)
Tape width	W	12.0±0.2(0.472±0.008)
Reel width	W1	16.8±2.0(0.661±0.079)

NOTE:Devices are packde in accordance with EIA standard RS-481-A and specification given above.